

Remote display

# RD 96

User manual and technical data

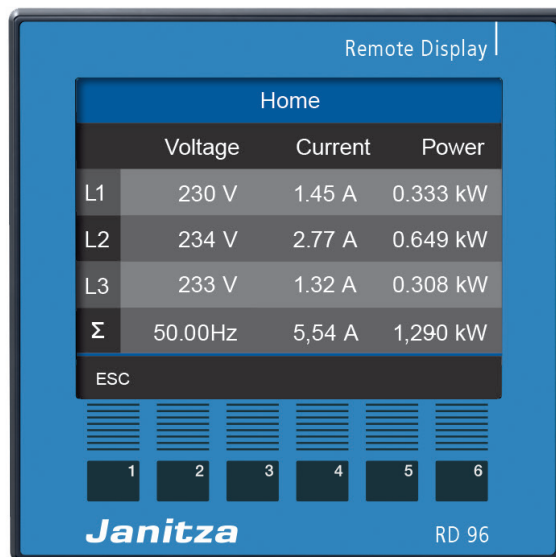
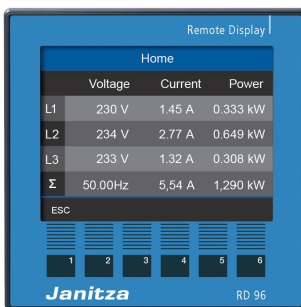

**Suitable basic devices**

UMG 801

*Tab. Suitable basic devices*

## RD 96

### Remote Display - External Display

Doc. no.: 2.029.006.1.a

Date: 04/2024

The German version is the original edition of the documentation

## Subject to technical alterations.

The contents of our documentation have been compiled with great care and reflect the current state of the information available to us. Nonetheless, we wish to point out that updates of this document are not always possible at the same time as technical refinements are implemented in our products. Please see our website under [www.janitza.com](http://www.janitza.com) for the current version.

Please see our website under [www.janitza.com](http://www.janitza.com) for the current version.

## Information about the GridVis® software.

 Janipedia: [wiki.janitza.de](http://wiki.janitza.de)

 Tutorials: [youtube.com/@gridvis](https://youtube.com/@gridvis)

## TABLE OF CONTENTS

<b>1. Information on the device and the user manual</b> .....	6
1.1 Disclaimer.....	6
1.2 Copyright notice.....	6
1.3 Technical changes.....	6
1.4 About this user manual.....	6
1.5 Defective device/disposal.....	7
<b>2. Safety</b> .....	8
2.1 Display of warning notices and safety information.....	8
2.2 Hazard levels.....	8
2.3 Product safety.....	9
2.4 Dangers when handling the device.....	9
2.5 Electrically qualified personnel.....	10
2.6 Warranty in the event of damage.....	10
<b>3. Product description</b> .....	12
3.1 Device description.....	12
3.2 Incoming goods inspection.....	13
3.3 Intended use.....	13
3.4 Performance characteristics.....	14
3.5 EU conformity declaration.....	14
3.6 FCC Declaration of Conformity.....	14
3.7 Scope of delivery.....	14
3.8 Accessories.....	14
<b>4. Structure of the device</b> .....	16
4.1 Front panel.....	16
4.2 Rear of the device.....	16
4.3 3D view.....	16
4.4 Identification of the device (rating plate).....	17

<b>5. Mounting</b> .....	18
5.1 Installation location.....	18
5.2 Mounting orientation .....	18
5.3 Securing .....	19
<b>6. Installation/Peripherals</b> .....	20
6.1 USB interfaces (Universal Serial Bus).....	20
6.2 Connection example with the UMG 801.....	20
<b>7. Operation and button functions</b> .....	22
<b>8. Service and maintenance</b> .....	24
8.1 Front panel foil and display.....	24
8.2 Service.....	24
8.3 Procedure in the event of a malfunction.....	25
<b>9. Technical data</b> .....	26
<b>10. Dimensional drawings</b> .....	28

## 1. Information on the device and the user manual

### 1.1 Disclaimer

Compliance with the usage information for the devices is a prerequisite for safe operation and attaining the stated performance characteristics and product features.

Janitza electronics GmbH assumes no liability for bodily injury, material damage or financial losses which result from disregard of the usage information.

Make sure that your usage information is readily available and legible.

### 1.2 Copyright notice

© 2020 - Janitza electronics GmbH - Lahnau.  
All rights reserved.

Any reproduction, processing, distribution or other use of this informational product, in whole or in part, is prohibited.

All trademarks and the rights arising from them are the property of the respective owners of these rights.

### 1.3 Technical changes

- Make sure that your device matches the user manual.
- This user manual is valid for the Remote Display RD 96 in conjunction with compatible Janitza DIN rail measuring devices. Separate validities and distinctions are marked.
- First read and understand the documents associated with the product.
- Keep the documents associated with the product available for the entire service life and pass them on to any possible subsequent users.
- Find out about device revisions and the associated modifications of the documentation associat-

ed with your product at [www.janitza.com](http://www.janitza.com).

### 1.4 About this user manual

If you have questions, suggestions or ideas for improvement of the user manual, please let us know via email at: [info@janitza.de](mailto:info@janitza.de).

---

### INFORMATION

**This user manual describes the RD 96 in conjunction with compatible Janitza DIN rail measuring devices and provides information on the operation of the device.**

**In addition to this user manual, please also consult the related usage information relevant to the previously mentioned devices, such as:**

- **Installation instructions.**
  - **Data sheets.**
  - **Safety information.**
  - **As applicable, documents for expansion modules.**
  - **Online help for the network visualization software GridVis®.**
-

## 1.5 Defective device/disposal

Before sending **defective devices, modules or components** back to the manufacturer for testing:

- Contact the manufacturer's Support department.
- Send devices, modules or components complete with all accessories.
- When doing so, please bear the terms for transportation in mind.

---

### **INFORMATION**

Please return defective or damaged devices to Janitza electronics GmbH in accordance with the shipping instructions for air or road freight (complete with accessories).

Observe special regulations for devices with built-in batteries or rechargeable batteries!

---

Do not attempt to open or repair the device (the component) on your own because otherwise all warranty claims become invalid!

For the **Disposal** of the device please observe national regulations! Dispose of individual parts, as applicable, depending on their composition and existing country-specific regulations, e.g. as

- Electronic waste,
- Batteries and rechargeable batteries.
- Plastics.
- Metals.

Engage a certified disposal company to handle scrapping as needed.

Information on service and maintenance of your device can be found in chapter „8. Service and maintenance“ on page 24.

## 2. Safety

The chapter on Safety contains information which must be observed to ensure your personal safety and avoid material damage.

### 2.1 Display of warning notices and safety information

The warning notices shown below

- are found throughout all of the documentation,
- can be found on the devices themselves,
- indicate potential risks and hazards,
- underscore aspects of the information provided that clarifies or simplifies procedures.



The additional symbol on the device itself indicates an electrical danger that can result in serious injuries or death.



This general warning symbol draws attention to a possible risk of injury. Be certain to observe all of the information listed under this symbol in order to avoid possible injury or even death.



### 2.2 Hazard levels

Warning and safety information is marked by a warning symbol, and the hazard levels are shown as follows, depending on the degree of hazard:

#### **DANGER**

Warns of an imminent danger which, if not avoided, results in serious or fatal injury.

#### **WARNING**

Warns of a potentially hazardous situation which, if not avoided, could result in serious injury or death.

#### **CAUTION**

Warns of an immediately hazardous situation which, if not avoided, can result in minor or moderate injury.

#### **ATTENTION**

Warns of an immediately hazardous situation which, if not avoided, can result in material or environmental damage.

#### **INFORMATION**

Indicates procedures in which there is **no** hazard of personal injury or material damage.

### 2.3 Product safety

The device reflects current engineering practice and accepted safety standards, but hazards can arise nonetheless.

Observe the safety regulations and warning notices. If notices are disregarded, this can lead to personal injury and/or damage to the product.

Every type of tampering with or use of this device,

- which goes beyond the mechanical, electrical or other operating limits can lead to personal injury and/or damage to the product;
- constitutes “misuse” and/or “negligence” under the product’s warranty and thus voids the warranty for any possible resulting damage.

Read and understand the user manual before installing, operating, maintaining and using the device.

Only operate the device when it is in perfect condition and in compliance with this user manual and the associated, included documents. Send defective devices back to the manufacturer in compliance with proper transport conditions. Retain the user manual throughout the service life of the device and keep it at hand for consultation.

When using the device, also observe the legal and safety regulations for your system that are applicable for the respective use case.

### 2.4 Dangers when handling the device

When operating electric devices, it is unavoidable for certain parts of these devices to conduct hazardous voltage. Consequently, severe bodily injury or material damage can occur if they are not handled properly.

Therefore, when handling our devices, always observe the following:

- do not exceed the limit values specified in the user manual and on the rating plate! This must also be observed during testing and commissioning!
- Safety and warning notices in all documents that belong to the devices!

#### **WARNING**

##### **Risk of injury due to electrical voltage!**

Severe bodily injury or death can result! Therefore please abide by the following:

- **Switch off your installation before commencing work! Secure it against being switched on! Check to be sure it is de-energized! Ground and short circuit! Cover or block off adjacent live parts!**
- **During operation and troubleshooting (especially for DIN rail devices), check your system for dangerous voltages and switch these off if necessary!**
- **Wear protective clothing and protective equipment in accordance with applicable guidelines when working on electrical systems!**
- **Before making connections to the device/the component, ground the device by means of the ground wire connection, if present.**
- **Do not touching bare or stripped leads that are energized! Equip stranded conductors with wire ferrules!**
- **Hazardous voltages can be present in all circuitry parts that are connected to the power supply.**
- **Protect wires, cables and devices with a suitable line circuit breaker/fuse!**
- **Never switch off, remove or tamper with safety devices!**
- **There can still be hazardous voltages present in the device or in the component even after it has been disconnected from the supply voltage (capacitor storage).**
- **Do not operate equipment with current transformer circuits when open.**
- **Only connect screw terminals with the same number of poles and design!**
- **Do not exceed the limit values specified in the user manual and on the rating plate! This must also be observed during testing and commissioning.**
- **Take note of the safety and warning notices in the documents that belong to the device!**

## 2.5 Electrically qualified personnel

To avoid bodily injury and material damage, only electrically qualified personnel are permitted to work on the devices and their components, modules, assemblies, systems and current circuits who have knowledge of:

- the national and international accident prevention regulations,
- safety technology standards,
- installation, commissioning, operation, disconnection, grounding and marking of electrical equipment,
- the requirements concerning personal protective equipment.

Electrically qualified persons within the scope of the technical safety information of all documents associated with the device and its components are persons who can furnish proof of qualification as an electrically skilled person.



### WARNING

**Warning against unauthorized manipulation or improper use of the device or its components!**

Opening, dismantling or unauthorized manipulation of the device and its components which goes beyond the mechanical, electrical or other operating limits indicated can lead to material damage or injury, up to and including death.

- **Only electrically qualified personnel are permitted to work on the devices and their components, assemblies, systems and current circuits.**
- **Always use your device or component only in the manner described in the associated documentation.**
- **If there is discernable damage, send the device or the component back to the manufacturer!**

## 2.6 Warranty in the event of damage

Any unauthorized tampering with or use of the device constitutes "misuse" and/or "negligence" under the product's warranty and thus voids the warranty of any possible resulting damage. In this regard, please take note of the section "3.3 Intended use".



### 3. Product description

#### 3.1 Device description

The RD 96 is an external display for reading out and configuring the compatible **DIN rail measurement device and its attached modules**.

The RD 96

- is designed for front panel installation within a switchboard cabinet or small distribution board.
- has 6 function buttons and ensures safe reading of measured values without having to open or touch live systems, system components, switchboard cabinets or small distribution boards!

A USB connection cable is included in the scope of delivery, which means the external display can be operated up to 1.8 m away from the Measuring device, within a switchboard cabinet or small distribution board.

The USB connection cable remains in the switchboard cabinet and must be laid separately from other electrical circuits! Please note the special rules for this in section „6.1 USB interfaces (Universal Serial Bus)“ on page 20.

---

#### **INFORMATION**

This user manual describes the **RD 96 in combination with a compatible measuring device**, possibly with modules, and provides information on the operation of the device.

With regard to this user manual, please pay particular attention to the usage information on the **Measuring device**, such as:

- Installation instructions.
  - Data sheet.
  - Safety information.
  - As applicable, documents for the expansion modules.
  - Online help for the network visualization software GridVis®.
- 



#### **CAUTION**

**Malfunction and damage of the device or risk of injury due to improper connection.**

Improperly connected devices can damage the device or pose a risk of injury to persons.

**Observe the following:**

- **For the specifications for connecting the RD 96 see section „6.1 USB interfaces (Universal Serial Bus)“ on page 20.**
- **Ground conductive front panels of switchboard cabinets or small distribution boards!**

### 3.3 Incoming goods inspection

Safe and trouble-free operation of this device and its components presupposes proper transport, proper storage, set-up and assembly as well as operation and maintenance in addition to compliance with the safety information and warning notices.

Exercise due caution when unpacking and packing the device, do not use force and only use suitable tools.

Before installing the device, please check the following:

- Its flawless mechanical condition by visual inspection.
- The scope of delivery for completeness.

If it can be assumed that safe operation of the device is no longer possible:

- Disconnect the device from operation immediately!
- Secure the device against being switched on again!

It can be assumed that safe operation is no longer possible if the device, for example:

- Has visible damage.
- No longer functions despite an intact power supply.
- Was subjected to extended periods of unfavorable conditions (e.g. storage outside of the permissible climate thresholds without adjustment to the room climate, condensation, etc.) or transport stress (e.g. falling from an elevated position, even without visible external damage, etc.).

### 3.2 Intended use

The external RD 96 display:

- is only for use in the industrial sector.
- is intended for front panel installation and connection of the top-hat rail meter mounted in the switch cabinet or small distribution board.
- is suitable for installation in fixed switchboard cabinets or small distribution boards, in any mounting orientation (front panel).
- is not intended for installation in vehicles! Use of the device in non-stationary equipment constitutes an exceptional environmental condition and is only permissible by special agreement.
- is not intended for installation in environments with harmful oils, acids, gases, vapors, dusts, radiation, etc.
- requires neither additional software nor drivers and functions using plug & play via the USB interface of the compatible measuring device.

Safe and trouble-free operation of the device requires proper transport, storage, assembly, installation, operation and maintenance.

### 3.5 Performance characteristics

#### General

- External display (for compatible Janitza DIN rail measuring devices) as a front panel installation device with the dimensions 96 x 96 mm (3.78 x 3.78 in).
- Connection via Universal Serial Bus (USB interface).
- Color graphic display 320 x 240 px.
- Operation via 6 buttons.
- Working temperature range -10 °C (14 °F) to +55 °C (131 °F).

### 3.8 EU conformity declaration

Please see the EU declaration of conformity posted at [www.janitza.de](http://www.janitza.de) for the laws, standards and directives applied by Janitza electronics GmbH for the devices. The CE conformity marking requirements for the device arise from the EU conformity declaration and the laws, standards and directives mentioned therein.

### 3.9 FCC Declaration of Conformity

The device:

- complies with Part 15 of the FCC Rules for Class B digital devices (limits to protect against harmful interference in a residential installation).
- generates, uses and can radiate high-frequency energy
- can cause harmful interference to radio communications if not installed and used properly. There is no guarantee that interference will not occur in a particular installation.

If there is radio or television reception interference, which can be determined by turning the device on and off, proceed as follows:

- Align or reposition the receiving antenna.
- Increase the distance between the device and the radio/television receiver.
- Connect the device and the radio/television receiver in different circuits.
- if necessary, contact Janitza support or a radio/television technician.

Code of Federal Regulations, Title 47, Part 15, Subpart B - Unintentional Radiators.

### 3.6 Scope of delivery

Quantity	Part. no.	Designation
1	52.31.212	RD 96 - External display
1	08.02.434	USB cable (type A plug to type B plug), 1.8 m (1.97 yd)
1	13.09.227	USB cover
1	33.03.390	Installation instructions DE/EN
1	33.03.342	Supplement "Safety Information"
1	52.22.251	Mounting kit

Tab. Scope of delivery

### 3.7 Accessories

Quantity	Part. no.	Designation
1	29.01.065	Silicone seal, 96 x 96 mm (3.78 x 3.78 in)

Tab. Accessories

### INFORMATION

- The mounting clamps required for the device are included in delivery.
- All supplied options and design variants are described on the delivery note.



## 4. Structure of the device

### 4.1 Front panel

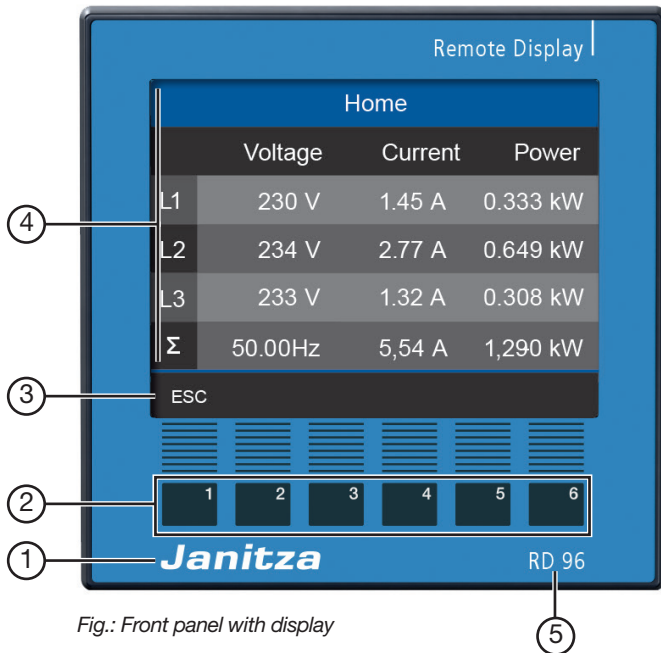

Fig.: Front panel with display

Item	Function/Designation
1	Manufacturer's logo
2	Function buttons
3	Display symbols of the button functions
4	Display for measured values and device configuration (Example: UMG 801)
5	Device designation
6	USB interface (2.0), type A
7	USB symbol
8	USB interface (2.0), type B (USB connection coming from UMG)
9	Application point for rating plate sticker

Tab: Device structure - Connections and controls

### 4.2 Rear of the device

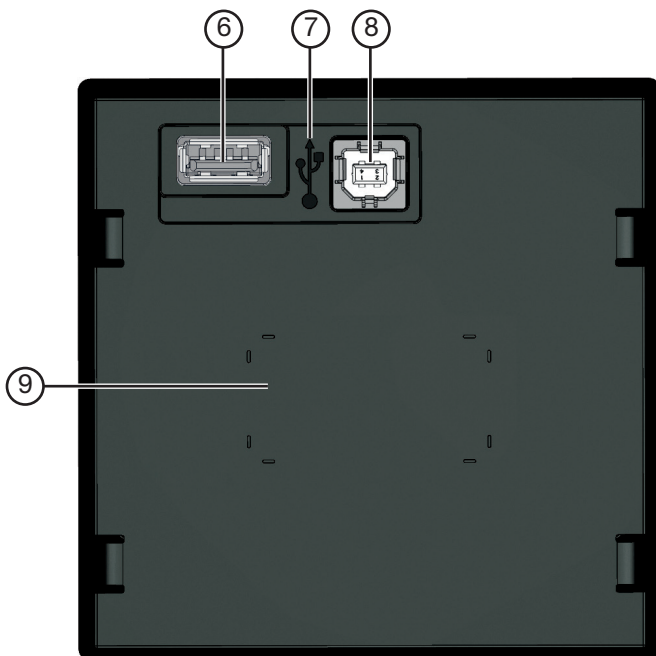

Fig.: Rear of the device

### 4.3 3D view



Fig.: Front panel with 3D display

#### 4.4 Identification of the device (rating plate)

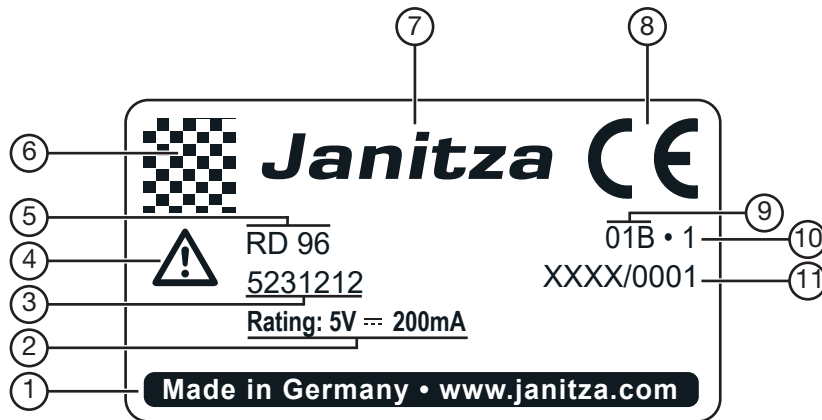

Item	Designation	Description
1	Designation of origin/web address	Country of origin and manufacturer's web address.
2	Operational data	Supply voltage and nominal current.
3	Part number of the device	Manufacturer's part number.
4	Symbol for "Danger sign"	General warning symbol. Be certain to observe the warning notices applied to the device and shown in the usage information in order to avoid possible injury or even death.
5	Device type	Device designation.
6	Data matrix code	Coded manufacturer data.
7	Manufacturer's logo	Logo of the device manufacturer.
8	CE conformity marking	See "3.5 EU conformity declaration" on page 25.
9	Manufacturer-specific data	Manufacturer data.
10	Hardware version	Hardware version of the device.
11	Type/serial number	Number for identification of the device.

Tab: Device identification, rating plate

## 5. Mounting

### 5.1 Installation location

<b>⚠ DANGER</b>
<p><b>Danger of electric shock!</b> Electric shocks lead to serious injuries, including death.</p> <ul style="list-style-type: none"> <li>· Disconnect your system from the power supply before mounting and connecting the device!</li> <li>· Secure it against being switched on!</li> <li>· Check to be sure it is de-energized!</li> <li>· Ground and short circuit!</li> <li>· Cover or block off adjacent live parts!</li> <li>· The installation must only be carried out by qualified personnel with electrical training!</li> </ul>

Mount the device in stationary and weatherproof front panels or switchboard panels of switchboard cabinets or indoor small distribution boards.

Ground conductive front or switchboard panels!

<b>ATTENTION</b>
<p><b>Material damage due to disregard of the installation instructions!</b> Disregard of the installation instructions can damage or destroy your device.</p> <ul style="list-style-type: none"> <li>· <b>Provide adequate air circulation in your installation environment and cooling, as needed, when the ambient temperatures are high!</b></li> </ul>

### 5.2 Mounting orientation

The cut-out dimension in the front panel or switchboard is  $92^{+0.8}$  mm x  $92^{+0.8}$  mm ( $3.62^{+0.03}$  in x  $3.62^{+0.03}$  in).

To ensure adequate ventilation of the device, take into account the minimum distances to adjacent components!

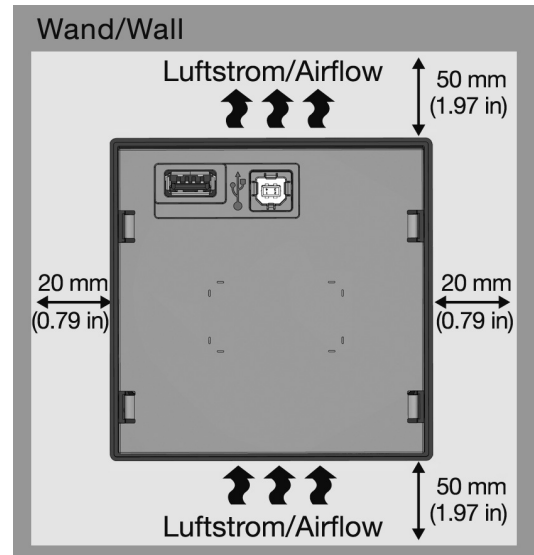

Fig.: Mounting orientation, rear view of RD 96 - minimum distances and air flow.

### 5.3 Securing

Secure the device inside the switchboard or on the front panel using the fastening clips on the side. To do so, proceed as follows:

- Before inserting the device, remove the fastening clips (e.g. with a screwdriver) by levering them horizontally.

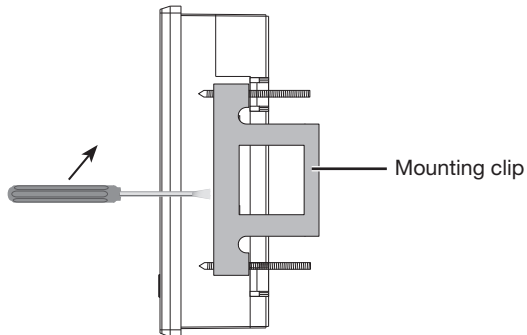

Fig.: Fig. Side view of the RD 96 with fastening clips.

- Insert the device through the front panel or switchboard from the front.
- Attach the clips to the side of the device by pushing them in and snapping them into place.
- Screw in the clamping screws until they touch the mounting plate.
- Then tighten the clamping screws with two further turns each. **Too tightly tightened clamping screws can destroy the fastening clips!**

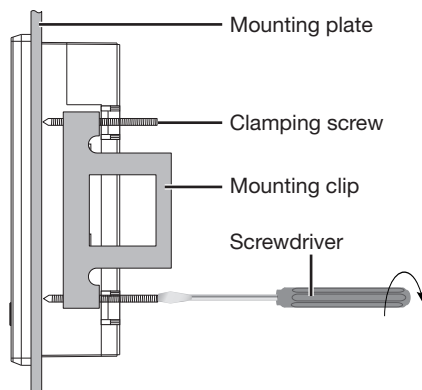

Fig.: Side view - fastening the RD 96

#### **i** INFORMATION

Once the clamping screws touch the mounting plate, turn them a max. of 2 further turns!

## 6. Installation/Peripherals

### 6.1 USB interfaces (Universal Serial Bus)

The RD 96 has 2 USB interfaces on the back for connection to the measurement device.

The USB serial bus system requires that the **Type A** USB interface on the **measuring device** be connected to the **Type B** USB interface on the **RD 96**.

The **Type A** USB interface on the RD 96 serves as a further serial connection to the bus system.

### 6.2 Connection example with the UMG 801

The following diagram shows the connection to the UMG 801 measuring device and serves as a connection example.

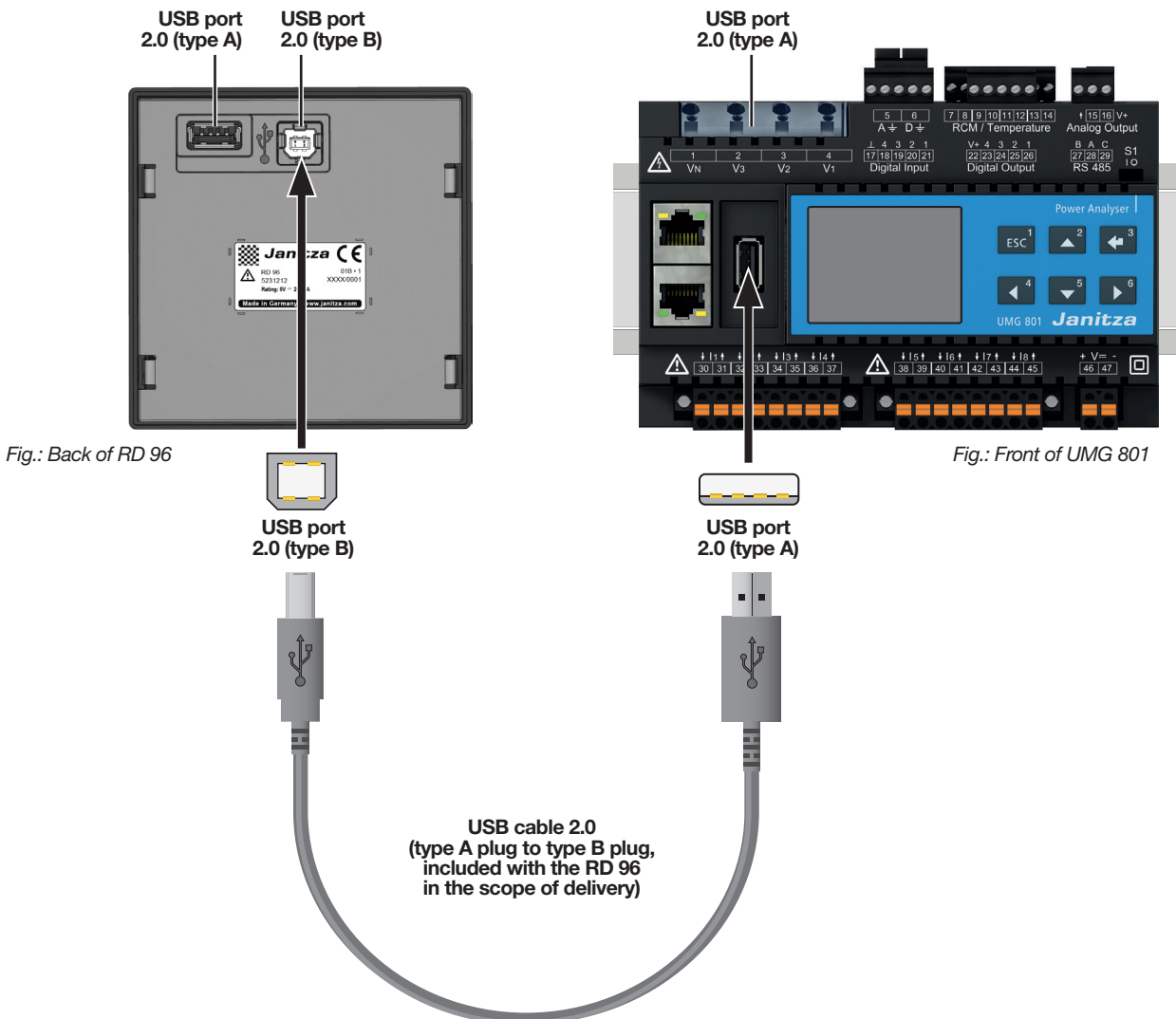

Fig.: Installation of the USB cable

**ATTENTION**

**Interference with the electrical safety and electromagnetic compatibility (EMC) of your electrical installation can arise due to laying cables and wires of different current types within an installation system.**

Laying communication cables and power cables in the same cable duct system can lead to interference in the communication cables (combination of emission, radiation or induction of unwanted electrical energy) and thus worsen the transmission quality of the communication data, even to the point of data loss.

- Lay lines and cables of different current types separated spatially from each other!
- Observe minimum distances for low voltage cables and data cables!
- Use separate cable duct systems or dividers within a cable duct system!
- Observe the essential basic conditions for electromagnetic compatibility (EMC) of communication cabling according to EN 50174 - Part 2.
- Please also observe the standard DIN VDE 0100-520 - Erection of low-voltage systems - which allows shared installation without additional separation if the dielectric strength is ensured by appropriate insulation between the power cable and the communication cable!

## 7. Operation and button functions

After connecting the USB cable, the measuring device display screen appears on the external display (RD 96) after a time delay.

Pressing function button 1 *ESC* takes you to the menu selection of the measurement device.

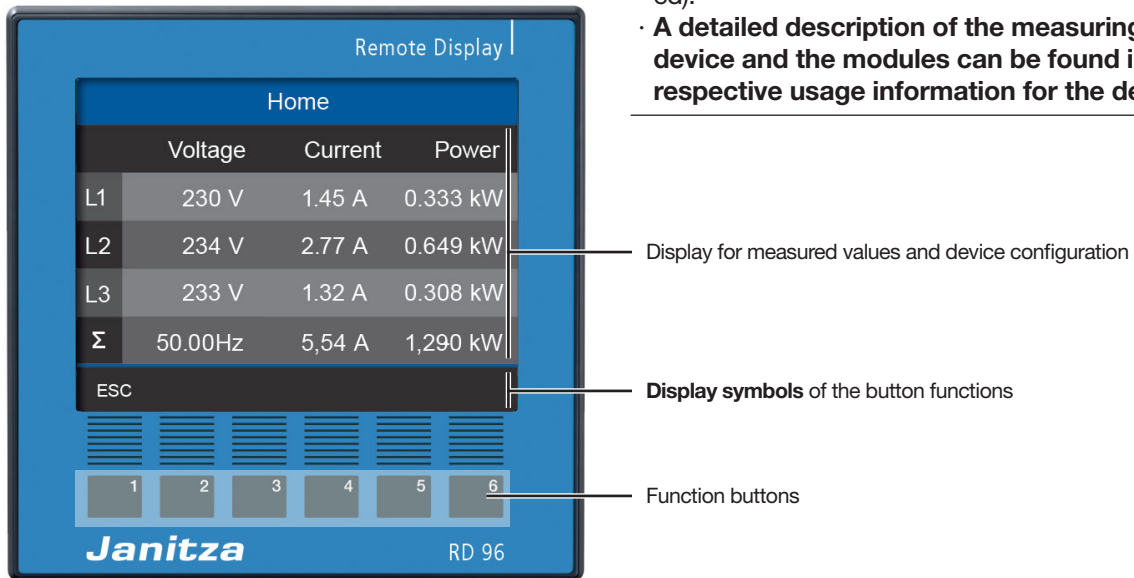

Fig. Example standard display, UMG 801 - RD 96

The RD 96 is operated using buttons with corresponding functions:

- Selecting measuring displays.
- Navigation within the menus.
- Device configuration.

The symbols on the display show the functions of the of the buttons.

### **i** INFORMATION

- During the system start-up (booting) of the measurement device, the RD96 display appears after a time delay (the time depends on the measurement device and the number of modules connected).
- **A detailed description of the measuring device and the modules can be found in the respective usage information for the devices.**



## 8. Service and maintenance

Prior to outbound delivery, the device is subjected to various safety tests and is marked with a seal.

### INFORMATION

For opened devices (damaged or removed seal):

- New safety inspections are required for safe operation!
- The warranty expires!

The warranty is only valid for unopened devices!

### WARNING

#### **Warning of unauthorized tampering or improper use of the device.**

Opening, dismantling or unauthorized manipulation of the device which goes beyond the mechanical, electrical or other operating limits indicated can lead to material damage or injury, up to and including death.

- **Only electrically qualified personnel are permitted to work on the devices and their components, assemblies, systems and current circuits!**
- **Always use your device or component only in the manner described in the associated documentation.**
- **In the event of visible damage, or for the purpose of repair and calibration, return the device to the manufacturer!**

### INFORMATION

This user manual describes the RD 96 in combination with DIN rail measuring devices and provides information on the operation of the device. In addition to this user manual, please also consult the related usage information relevant to the used devices, such as:

- Installation instructions.
- Data sheets.
- Safety information.
- As applicable, documents for expansion modules.
- Online help for the network visualization software GridVis®.

### 8.1 Front panel foil and display

Please note the following for the care and cleaning of the front foil and the display:

#### **ATTENTION**

#### **Material damage due to improper care and cleaning of the device.**

The use of water or other solvents, such as denatured alcohol, acids, acidic agents for the front foil or the display can damage or destroy the device during cleaning. Water can, for example, penetrate into the device housing and destroy the device.

- **Clean the device, the front foil or the display with a soft cloth.**
- **Use a cloth moistened with clear water for heavy soiling.**
- **Clean the front foil and the display, e.g. of fingerprints, with a special LCD cleaner and a lint-free cloth.**
- **Do not use acids or acidic agents to clean the devices.**

### 8.2 Service

For questions not answered or described in this manual, please contact the manufacturer. Please be certain to have the following information ready to answer any questions:

- Device designation (see rating plate).
- Serial number (see rating plate).
- An exact error description.

### 8.3 Procedure in the event of a malfunction

Failure mode	Cause	Remedy
No display	External fuse for the supply voltage of the basic device has tripped.	Replace fuse.
	USB cable not connected or connected incorrectly.	Obtain information on the correct USB cable specifications and reconnect the device.
	Basic device does not contain the latest firmware.	Update the firmware of the basic device using the GridVis® software.
Despite the above measures, the device does not function.	Device defective.	Send the device and error description to the manufacturer for inspection.

*Tab: Procedure in the event of a malfunction*

---

#### **INFORMATION**

In case of a fault, please also observe the particulars in the usage information of the measuring device.

---

## 9. Technical data

General	
Net weight	approx. 140 g (0.31 lbs)
Package weight (incl. accessories)	approx. 440 g (0.97 lbs)
Dimensions W x H x D without mounting clamps	96 mm x 96 mm x 30 mm (3.78 in x 3.78 in x 1.18 in)
Backlight service life	40000 h (after 40000 h the backlight goes down to approx. 50%)
Impact resistance	IK07 according to IEC 62262

Transport and storage	
The following specifications apply for devices transported and stored in the original packaging.	
Free fall	1 m (39.37 in)
Temperature	-25° C (-13 °F) to +70° C (158 °F)
Relative air humidity (non-condensing)	0 to 90% RH

Environmental conditions during operation	
Install the device in a weather-protected and stationary location. Protection class II according to IEC 60536 (VDE 0106, Part 1).	
Rated temperature range	-10 °C (14 °F) to +55 °C (131 °F)
Relative air humidity (non-condensing)	0 to 75% RH
Operating elevation	0-2000 m (6562 ft) above sea level
Pollution degree	2
Mounting orientation	As desired
Ventilation	No forced ventilation required.
Protection against foreign matter and water	IP40 according to EN60529 IP20 according to EN60529 IP54 according to EN60529
- Front	
- Rear	
- Front with seal	

Serial interface (USB)	
USB 2.0 (type A)	1x
USB 2.0 (type B)	1x
Supply voltage	DC 5 V
Nominal current	200 mA
Operating range	+/-5% of nominal range
Power consumption	1 W

USB cable (included in delivery)	
USB 2.0 (type A to type B connector)	1.8 m (1.97 yd)

### INFORMATION

Please also observe the technical data in the measuring device usage information, such as:

- User manual.
- Installation instructions.
- Data sheet.
- Safety information.
- As applicable, documents for expansion modules.
- Online help for the network visualization software GridVis®.



## 10. Dimensional drawings

- The figures are for illustration purposes only and are not to scale.
- All dimensions in mm (in).

Fig. Bottom view

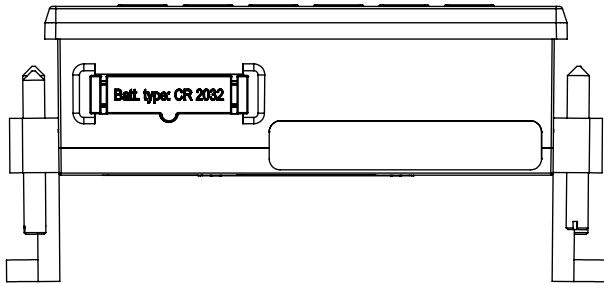

Fig. Front view

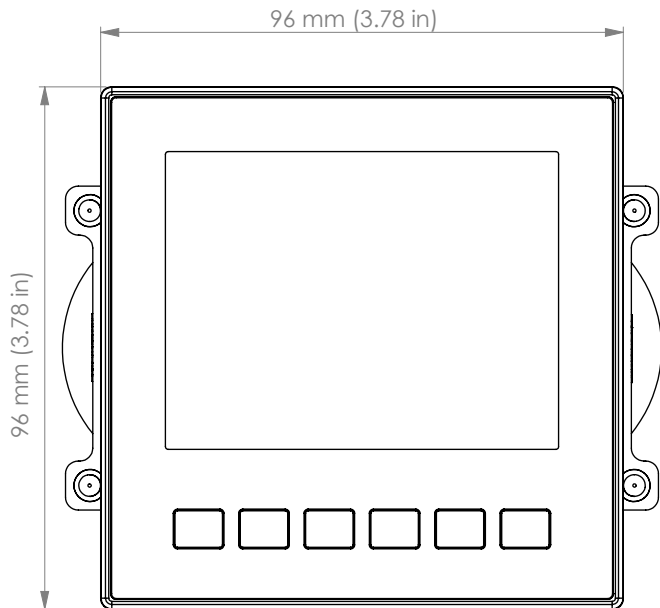

Fig. Side view

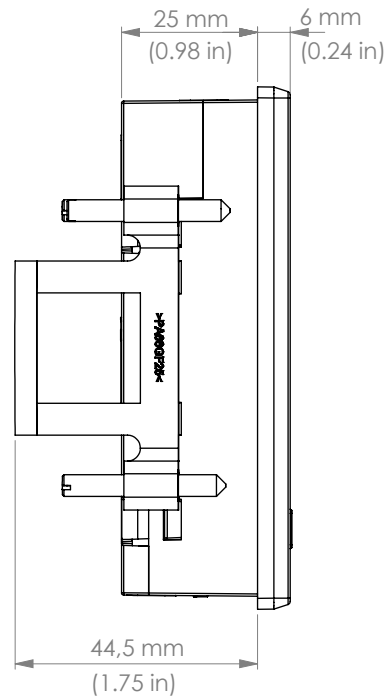

Fig. Top view

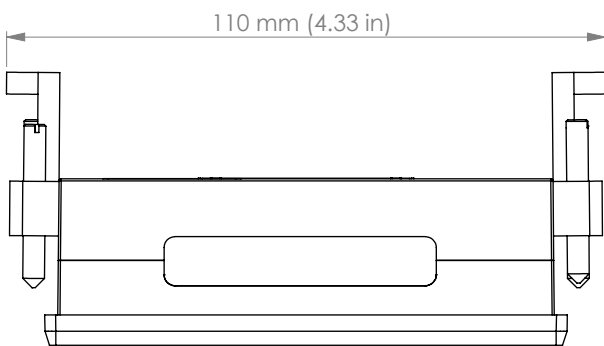

Fig. Rear view

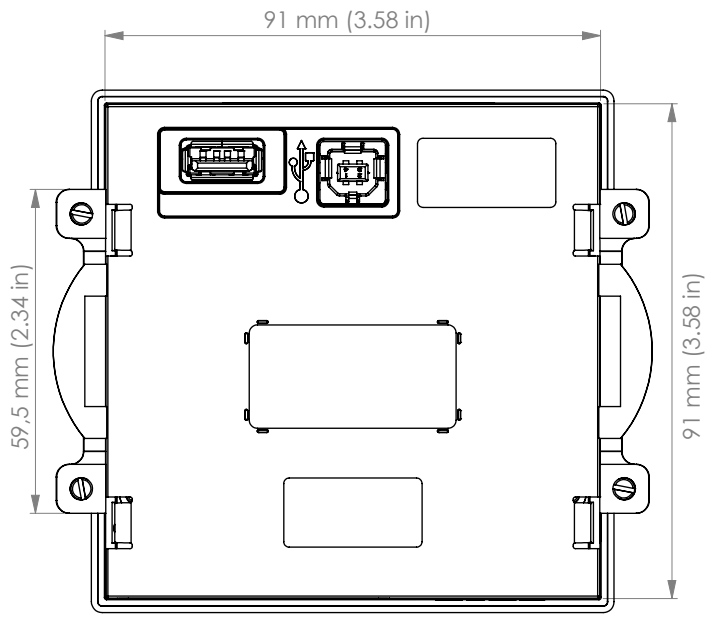
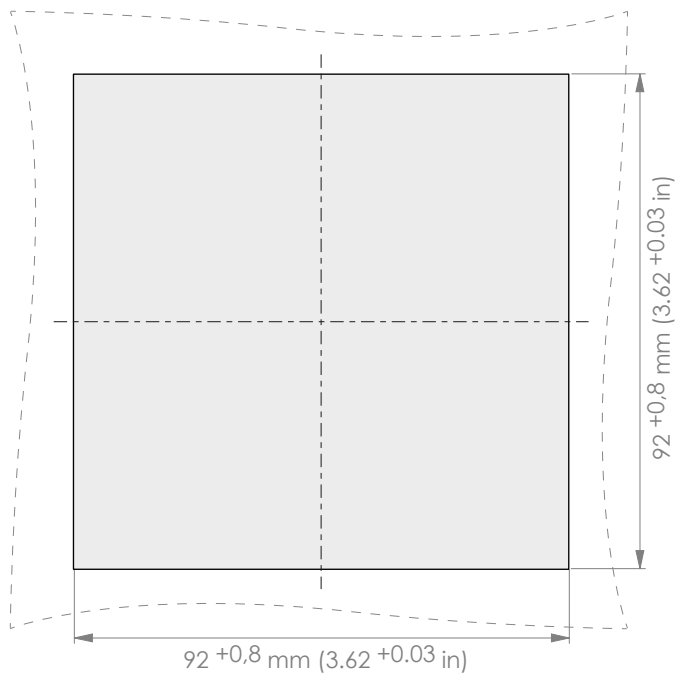

Fig. Cutout dimensions



***Janitza***<sup>®</sup>

Janitza electronics GmbH  
Vor dem Polstück 6 | 35633 Lahnau  
Germany

Tel. +49 6441 9642-0  
info@janitza.com | www.janitza.com