



THE CHALLENGE OF
HIGH AVAILABILITY

RESIDUAL CURRENT MONITORING

Added safety, higher system availability, reduced fire hazard

Janitza[®]



TABLE OF CONTENTS

4 Benefits of residual current monitoring (RCM)

8 Overview of residual current types

12 Holistic energy and residual current monitoring

6 The monitored TN-S system

10 Effects of residual currents on operating equipment

14 Structure of a residual current monitoring system with Janitza

7 Power supply with no blackouts

11 Increased fire hazard and premature wear



16 UMG 509-PRO &
UMG 512-PRO

19 JPC 100-WEB –
Smart Energy Panel

24 GridVis® – Power Grid
Monitoring Software

17 UMG 96-PA

20 UMG 20CM &
Module 20CM-CT6

26 Overview of residual current
transformers

18 UMG 96RM-E

22 RCM 201-ROGO &
RCM 202-AB

31 Compatibility list for
residual current transformers



BENEFITS OF RESIDUAL CURRENT MONITORING

Residual current monitoring (RCM) is becoming an increasingly important for applications requiring highly available power supplies. With continuous residual current monitoring, you keep your low-voltage network under control. Hazardous residual currents that could lead to system malfunctions or increase the risk of fire are detected immediately so that production downtime can be avoided.

RCM measurement devices from Janitza, such as the RCM 202-AB, RCM 201-ROGO / UMG 512-PRO / UMG 509-PRO / UMG 96RM-E / UMG 96-PA and UMG 20CM, are suitable for monitoring alternating currents, pulsating direct currents – according to IEC/TR 60755 (2008-01) – for Type A and Type B/B+ (RCM 202-AB) and can be used for continuous checking of residual currents in TN-S systems.

Applications can be found in almost all market segments, especially when it comes to continuous processes and especially sensitive applications. For example, data centers, hospitals or semiconductor factories rely on RCM monitoring. Wherever insulation monitoring devices (IMD) and residual current protective devices (RCD) cannot be realized due to local or operational conditions, continuous RCM measurement offers a good alternative.



Further information and the detailed RCM white paper can be found at: <https://www.janitza.com/whitepaper-about-rcm.html>

Residual current monitoring



AVOID SYSTEM FAILURES



SIGNALING INSTEAD OF SHUTDOWN



IMPROVE FIRE PROTECTION



MAINTENANCE COST OPTIMIZATION



PREVENT PRODUCTION INTERRUPTIONS



MONITOR HIGHLY AVAILABLE ENERGY DISTRIBUTION SYSTEMS

ADDED VALUE AND SAVINGS POTENTIALS

- Early detection and reporting of residual currents through continuous monitoring
- Continuous monitoring of proper function in TN-S systems
- Adherence to EMC and minimization of interference on grounded equipment and thus, increased system availability
- Reduced testing effort on stationary electrical systems within the scope of German Social Accident Insurance (DGUV) Regulation 3 for electrical operational safety, IEC 60364-6:2016
- Insulation measurements on fixed electrical systems and the associated shutdown can be omitted

- No danger to sensitive loads that could be damaged by a high test voltage
- No high personnel and administrative expenses due to shutdowns and thus reduced costs
- Maximum alternative safety in areas where RCDs cannot be used for operational reasons
- Early warning system for RCDs and ground fault circuit breaker
- High connectivity and retrofitting capability in new and existing systems
 - Indispensable for TN-S systems requiring high availability!

THE MONITORED TN-S SYSTEM

EMC COMPATIBLE AND HIGHLY AVAILABLE POWER SUPPLY WITHOUT FORCED SHUTDOWNS

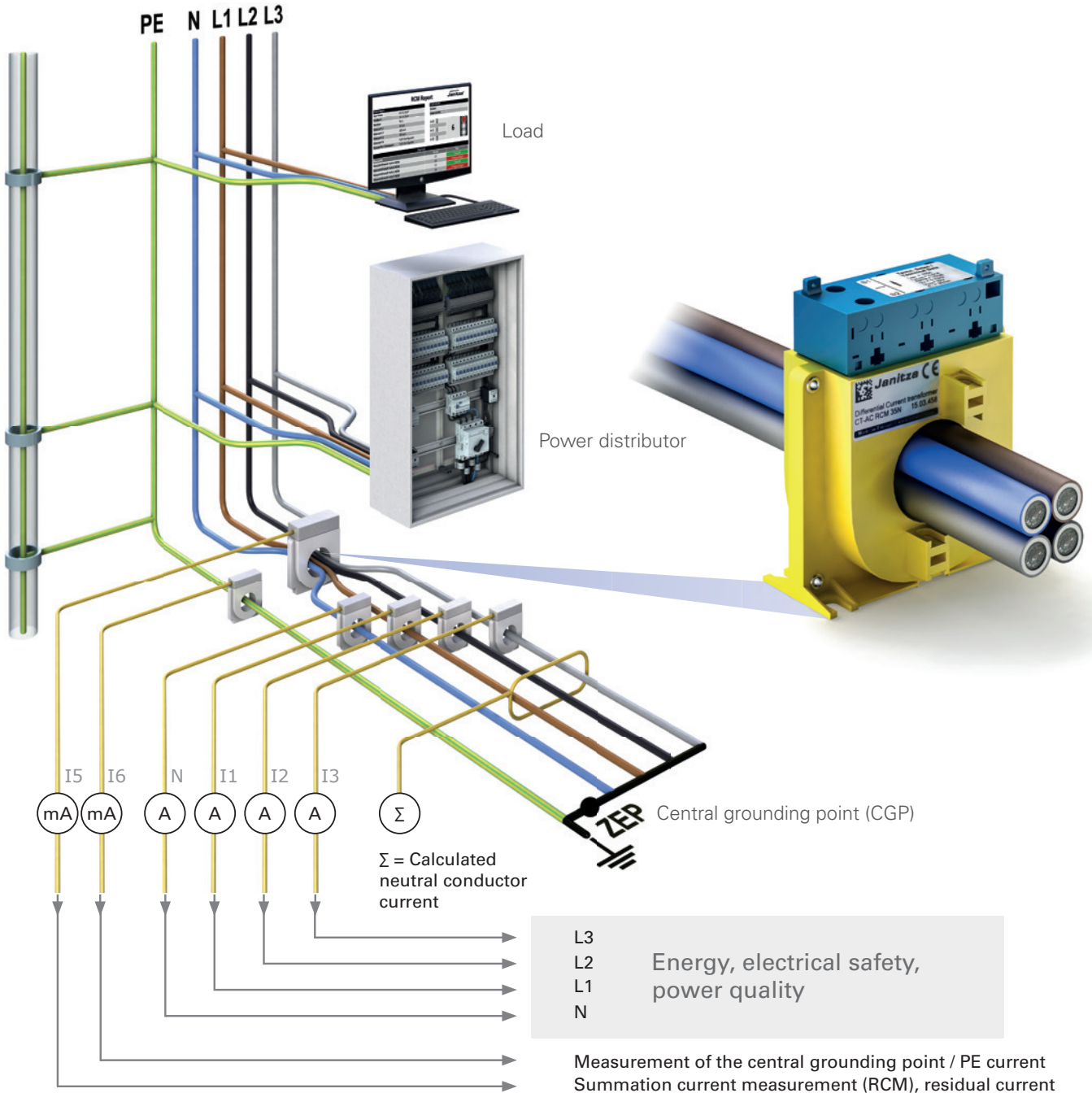

Residual and operating current monitoring: Can be implemented with the UMG 512-PRO / UMG 509-PRO / UMG 96RM-E and UMG 96-PA network analyzers (with RCM module). The RCM device used should be easy to handle, automatically point out problems and at the same time provide valuable assistance to the service technician.

POWER SUPPLY WITH NO BLACKOUTS

TN-S systems are mandatory for new installations. Conversion to TN-S systems is also recommended for older TN-C-S systems. The functionality of TN-S systems can be monitored and logged continuously with Janitza RCM solutions.

In many industries and application areas, this requirement represents a key function for the safety and economic success of the company.

In practice, all three phases and the neutral conductor run through the summation current transformer. In systems without a neutral conductor, for example with controlled drives, only the three phases are fed through the summation current transformer. When the system is in the fault-free state, the summation current is zero or close to zero (within the tolerance range), so that the current induced in

the secondary circuit is also zero or close to zero. If, on the other hand, a residual current flows to ground in the event of a fault, the current imbalance in the secondary circuit causes a current to be detected, reported and evaluated by the RCM measurement device.

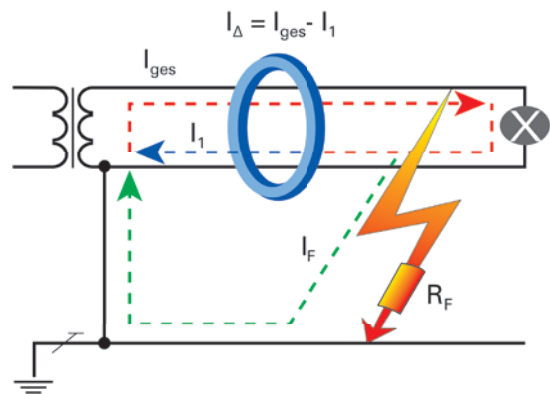



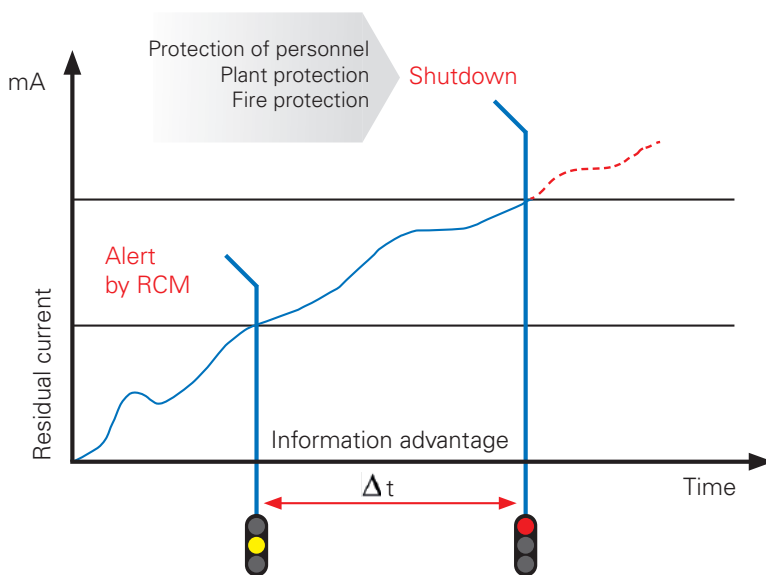





EARLY REPORTING INSTEAD OF SWITCHING OFF

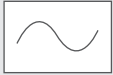
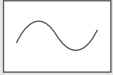

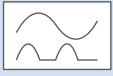
Alert before switching off – An objective of residual current monitoring

The decisive factor is to detect any disturbances early on, **before** fuses or residual current devices (RCDs) of affected systems or socket power circuits are switched off. To do so, the increases in residual currents, which are typically very gradual (e.g. triggered by insulation faults and operating currents of system components or consumers that become too high), must be monitored, evaluated and reported before failures occur!

OVERVIEW OF RESIDUAL CURRENT TYPES

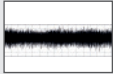
Application	Type of residual current	Residual current shape	Where used	Functions correctly with
Ohmic consumers, purely inductive and capacitive consumers, lighting systems with CB and transformer, direct-starting motors without electronic regulation and control, etc.	Sinusoidal alternating current		No longer up to date, as there are hardly any systems with only equipment of this type	 Type AC AC current sensitive
Single-phase electronic devices and devices with electronic regulation and control such as: power supplies, computers, lighting systems with electronic ballast or electronic transformers, single-phase drives, heat pumps, etc.	Pulsating alternating current (positive or negative half-wave)		All areas, especially single phase e.g. apartments, small offices, etc.	Standard switches for modern households  Type A Alternating current + pulse current sensitive
Single-phase dimmers and devices with phase-angle or phase cut-off control	Phase angle controlled half-wave currents Phase angle of 90° el and 135° el			
Single-phase electronic devices operated in the three-phase network distributed over the phases (a small direct current component is produced by superimposing pulsating residual currents)	Pulsating alternating current superimposed on smooth direct current of max. 6 mA			
Devices with three-phase bridge circuits and purely direct current systems, e.g. photovoltaic systems (collector-side)	Smooth direct current		Industry, especially 4-pole, for PV systems also 2-pole DC and in all systems where purely DC residual currents can occur, e.g. construction sites	  Type B Alternating current + Pulsed current + Direct current = All-current sensitive
Controlled three-phase drives (FC), e.g. controlled three-phase motors, three-phase UPS systems, three-phase dimmers, med. three-phase devices, etc.	High frequency, up to 1000 Hz and above			

Residual current types

Type A

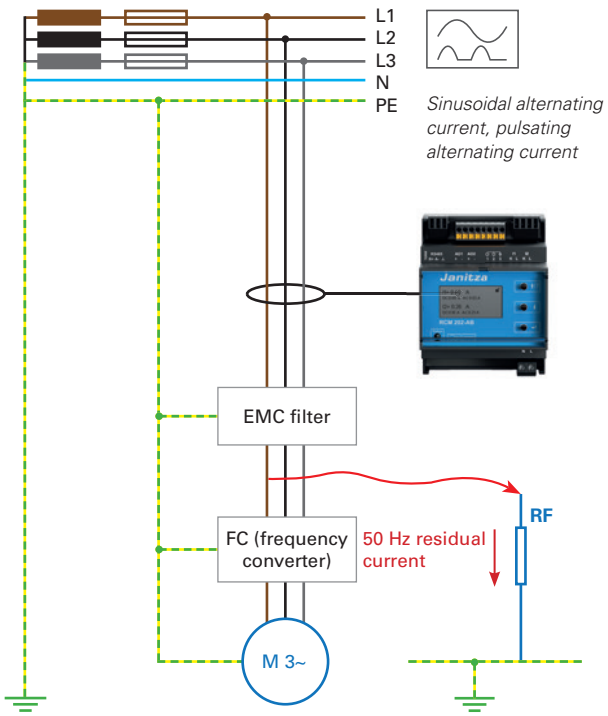

Type B

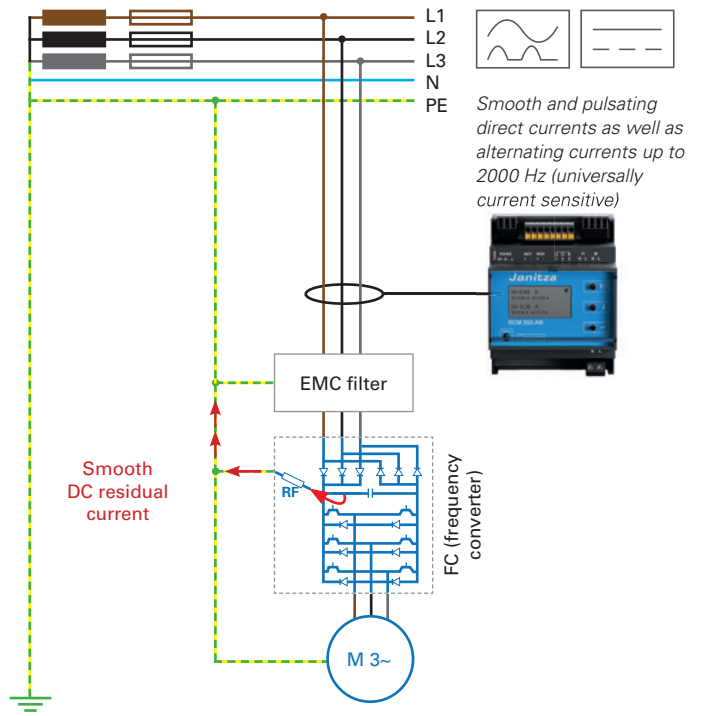

Type B+

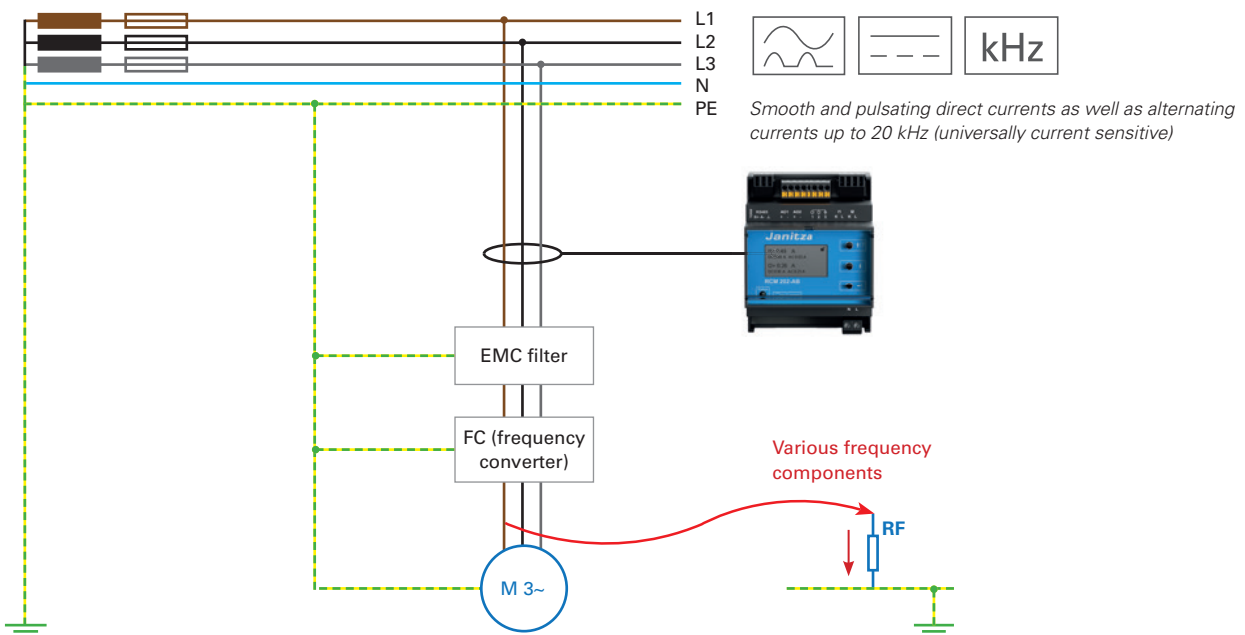

EFFECTS OF RESIDUAL CURRENTS ON EQUIPMENT

Supply and return conductors should also be arranged close together in distributions to minimize magnetic fields. At each node of a circuit, the sum of the currents must be zero to avoid residual currents. With RCM monitoring, the correct status is checked continuously.

Vagrant currents disturb the EMC. Incorrect connections between N and PE conductors lead to "vagrant" operating currents being distributed via the PE system, data lines and all metal parts of the building. Because these currents are not balanced, they generate electromagnetic fields. The consequences are many types of disturbances in the electrical systems, EDP networks and piping systems of the building installation. The diagram below illustrates how the operating current is divided at the PEN bridge and can

flow back over several paths, which means that the sum of the currents over the supply and return conductors is no longer 0.

This can cause the following disturbances:

- Change in the operating behavior of frequency-dependent components (e.g. capacitors consume more current)
- Disturbance of data transmissions due to magnetic and inductive influences
- Transmission of lightning influences into the electrical system
- Corrosion on metallic pipes
- Influence on persons

IMPERMISSIBLE OPERATING CURRENTS ON GROUNDING SYSTEMS AND DATA LINES

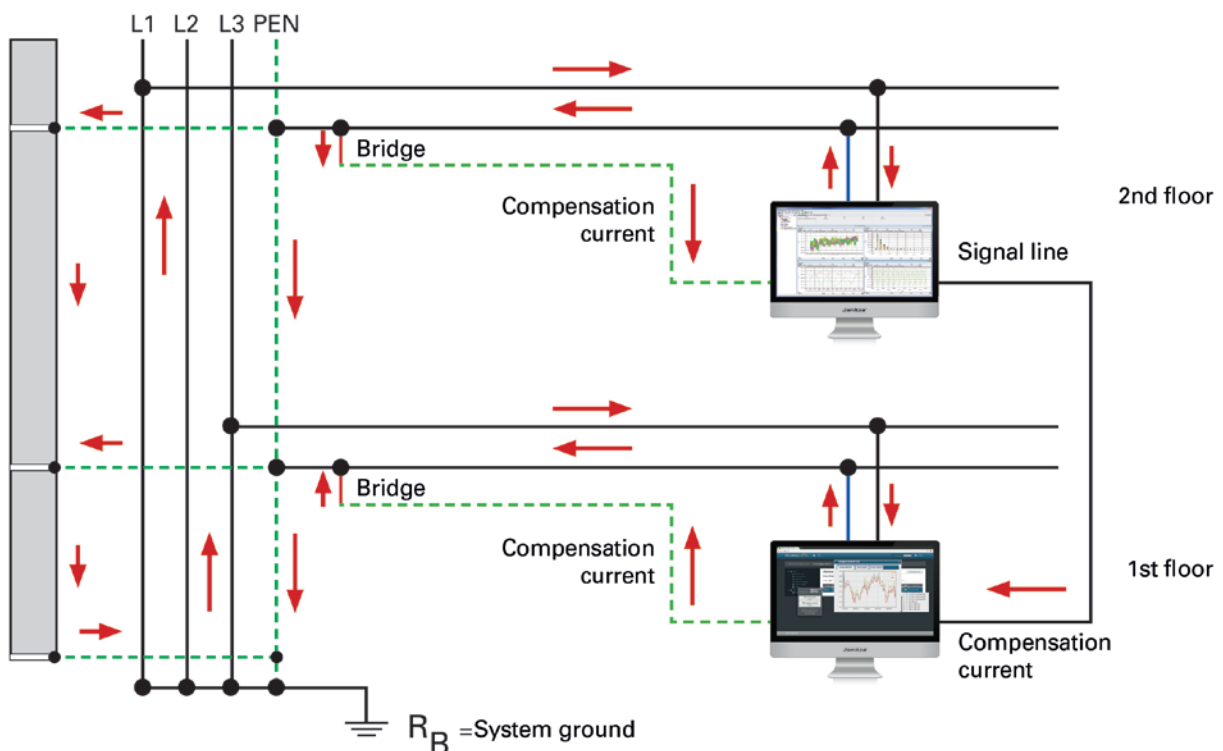

INCREASED FIRE HAZARD

About 31% of all fires are caused by electricity. As of a residual current of approx. 300 mA (60 watts at 230 V), there is an increased risk of fire. With continuous RCM monitoring,

you can detect excessive residual currents and react in good time.

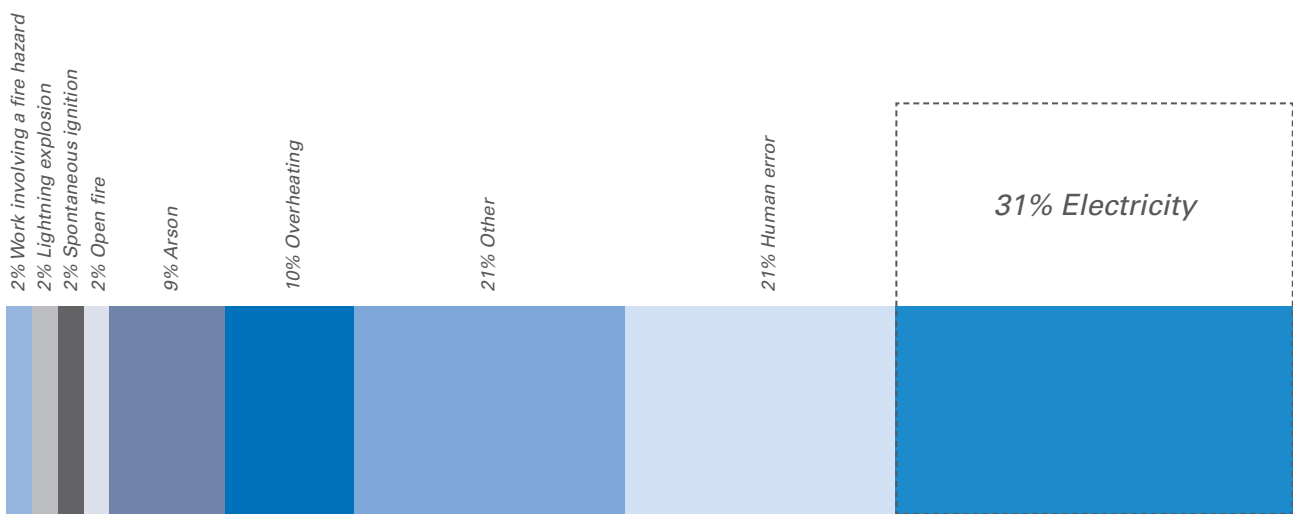

Source: IFS Damage Database*

*<https://www.ifs-ev.org/schadenverhuetung/ursachstatistiken/brandursachenstatistik/>

PREMATURE WEAR OF EQUIPMENT DUE TO RESIDUAL CURRENTS

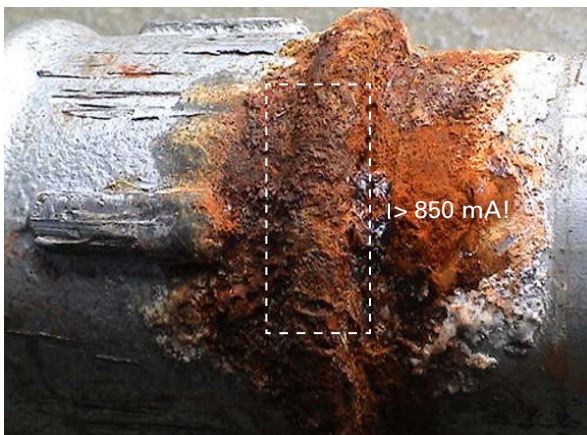

Impermissible currents on equipment: Damage patterns of corroded water pipes in affected piping systems are irregular, localized corrosion patterns, pitting and crater-like rust formation.

HOLISTIC ENERGY & RESIDUAL CURRENT MONITORING

MAIN POWER SUPPLY, CGP AND IMPORTANT NODES

SECONDARY DISTRIBUTION

END CONSUMERS & FINAL CIRCUITS

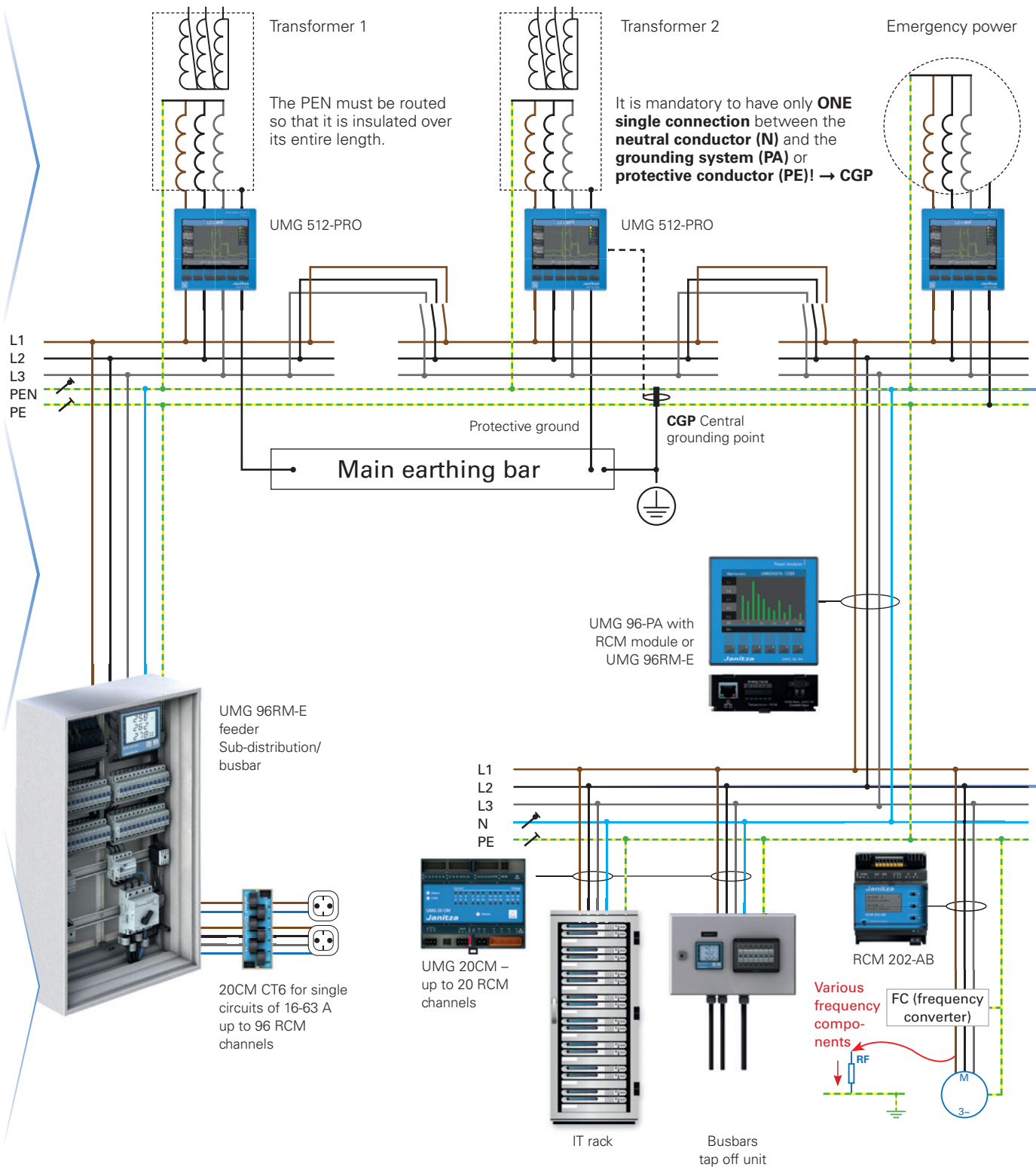

ACROSS ALL LEVELS FROM THE FEEDER TO THE FINAL CIRCUIT

Comprehensive RCM monitoring of the power supply is carried out at all levels – from the CGP and outgoing feeders requiring monitoring in the low-voltage main distribution board (LVMDB), on to subdistribution panels and individual critical loads.

MAIN POWER SUPPLY, CGP AND IMPORTANT NODES



6-channel operating current, residual current and power quality

UMG 509-PRO & UMG 512-PRO

- Power quality monitoring valid for legal purposes to class A (only UMG 512-PRO)
- Recording of operating and residual currents
- Ideal for feeders
- Monitoring mode for fluctuating and constant loads

RCM 201-ROGO

- Ideal for busbars or large conductor cross-sections

SECONDARY DISTRIBUTION



6-channel operating and residual current

UMG 96RM-E

- Recording of operating and residual currents
- Ideal for larger outgoing feeders and sub-distributors
- Monitoring mode for fluctuating and constant loads

UMG 96-PA & RCM module

Modular retrofitting capability

RCM 202-AB

Residual currents of type A, type B, type B+

END CONSUMERS & FINAL CIRCUITS



20 + 96 RCM channels = 116 channels

Multi-channel operation and residual current monitoring

UMG 20CM

- Ideal for many outgoing feeders and circuits
- Monitoring mode for constant loads
- Header device for the 20CM-CT6

20CM-CT6

- Expandable by up to 96 current channels
- Measured value acquisition in parallel via six integrated current transformers

RCM 202-AB

Residual currents of type A, type B, type B+

GridVis®

The strategic system software for energy data, power quality and RCM in one system

STRUCTURE OF A RESIDUAL CURRENT MONITORING SYSTEM WITH JANITZA

Janitza network analyzers allow a modular and flexible system design over the entire power supply. All measurement devices have at least one Modbus RTU interface. Depending on the type, however, also via Modbus TCP/IP, SNMP, BACnet IP, Profibus or Profinet. This allows an integration into previously existing BMS systems with no complicated detours via proprietary protocols. An extensive range of RCM diagnostic variables is available to implement an optimal monitoring solution.

In addition, the GridVis® Power Grid Monitoring Software can be used to manage and visualize all devices. Automated RCM test reports facilitate evaluation and verification.

The Smart Energy Panel JPC 100-WEB is used for the visualization and monitoring of measured energy values and operating currents on site. It is the tailor-made solution for state monitoring referenced to the specific system.

MAIN DISTRIBUTION AND IMPORTANT NODES

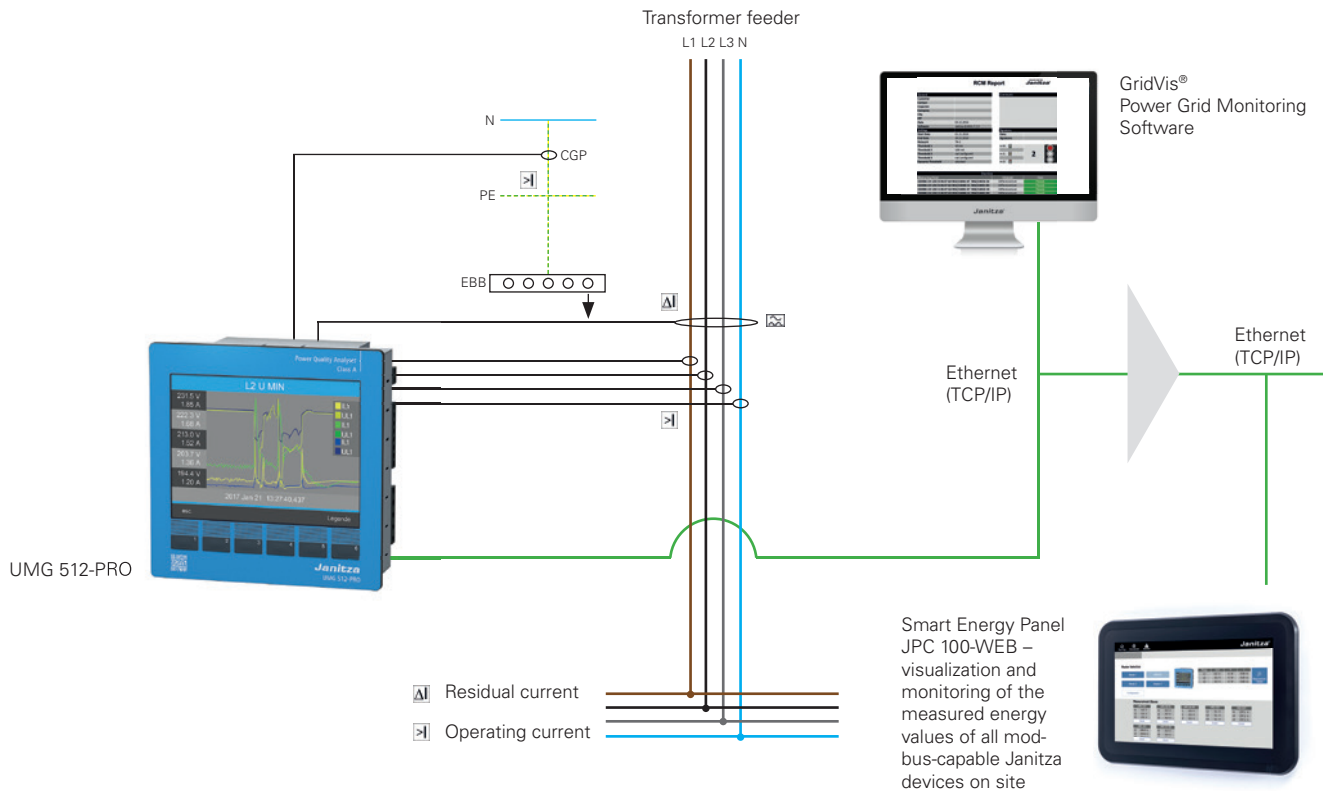

Residual current monitoring

The planning can be divided into the following steps:

- Risk assessment
- Define measurement points (in the case of residual currents, it must be possible to locate sources of errors quickly)
- Structure distributions measurably
- Label CGP and test sites so they are clearly visible
- Define, document and set limit values
- Define two independent signaling paths (local signaling, signaling in permanently manned control center)
- Test the signaling paths by introducing errors (functional test)
- Train personnel on site (actions in case of errors)

- Limit value per measurement channel
- Extensive Modbus RCM diagnostic variables for higher-level systems
- Step function for threshold values
- Residual current status per channel
- Fixed RCM threshold value
- Transformer connection check per channel
- Email alarms
- Dynamic RCM threshold value
- Digital alarm outputs

JANITZA NETWORK ANALYZERS

OUTGOING FEEDERS, SUB-DISTRIBUTORS AND END CONSUMERS

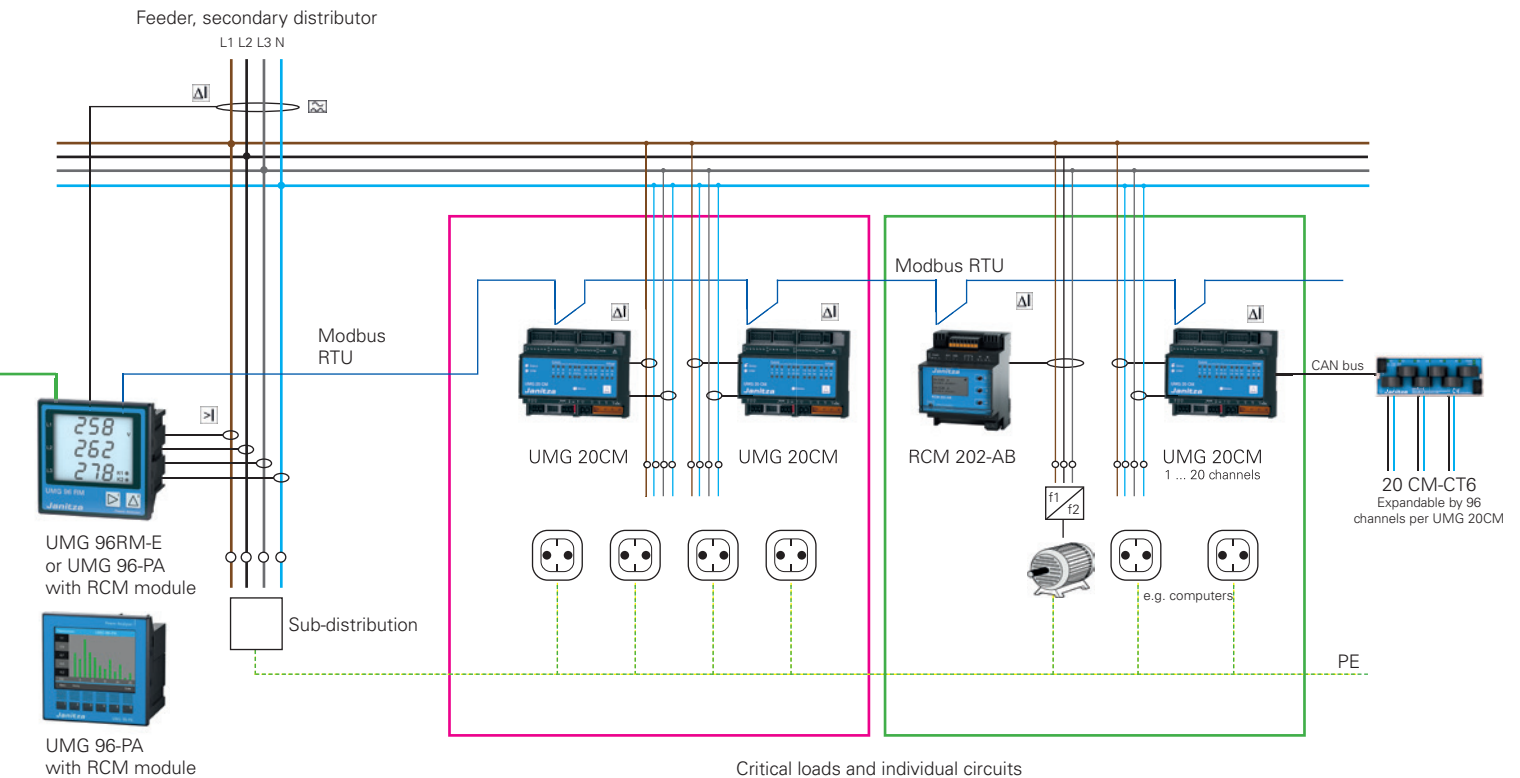

RCM & POWER QUALITY

CONTINUOUS OPERATING & RESIDUAL CURRENT MONITORING

Main power supply, CGP and important nodes

The UMG 512-PRO and UMG 509-PRO power quality analyzers are used at important junctions of TN-S networks to monitor the power quality and for energy data management. The Ethernet-capable devices have different IP protocols and interfaces and can be easily integrated into higher-level systems (such as PLC, SCADA solutions, etc.) via a variety of communication structures.

The UMG 509-PRO network analyzer is an all-rounder for the continuous monitoring of power quality as well as for analyzing electrical disturbance variables in the event of network problems. The UMG 512-PRO is a class A certified power quality analyzer according to IEC 61000-4-30. Power quality parameters such as harmonics up to the 63rd order, flicker, short-term interruptions, etc., are measured according to class A.

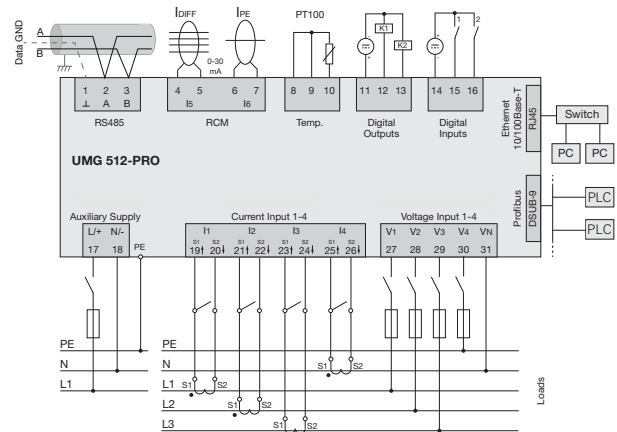

- | | | |
|--|---|--|
| <ul style="list-style-type: none"> ■ Class A certified according to IEC 61000-4-30 (UMG 512-PRO) and EN50160*/61000-2-4 ■ Network compatibility level, total residual currents and energy for higher system availability ■ Monitoring of electrical high availability | <ul style="list-style-type: none"> ■ Detection of residual currents and monitoring of the total residual current in a TN-S system ■ RCM limit values can be optimized for each use case – with a fixed or dynamic limit value ■ RCM diagnostic variables | <ul style="list-style-type: none"> ■ Historical data – long-term monitoring of measured variables ■ Dynamic CGP limit values based on the total energy ■ Alarm outputs ■ Harmonics up to the 63rd harmonic |
|--|---|--|

UMG 512-PRO/UMG 509-PRO

* UMG 509-PRO only as a reference

RCM & ENERGY MEASUREMENT WITH MID

RECORDING OF OPERATING AND RESIDUAL CURRENT

Secondary distribution

The energy measurement devices of the UMG 96-PA series combine various functions such as energy management and power quality monitoring in one device. The UMG 96-PA-MID and UMG 96-PA-MID+ versions also have MID certification. The residual current measurement can also be supplemented with the optional RCM module.

Residual currents and leakage currents are detected and recorded with reference to ground according to IEC 60755 type A and B. An additional 1/5 A current input is available for neutral conductor monitoring. An Ethernet port simplifies the connection to higher-level systems.

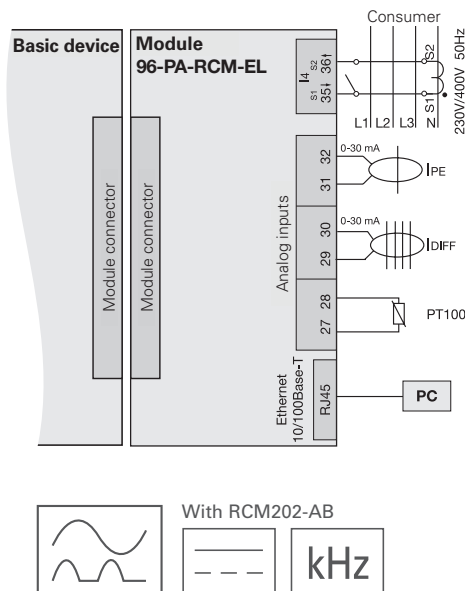

- MID measurement: Manipulation-proof and legally binding acquisition of energy data
- Historical data – long-term monitoring of measured variables
- RCM limit values can be optimized for each use case – with a fixed or dynamic limit value
- Ethernet connection
- RCM diagnostic variables
- Fourth current transformer input (e.g. N conductor)
- The UMG 96-PA module has an integrated thermistor input for thermocouples
- Two analog inputs: Optionally as 0 - 20 mA analog inputs or as RCM measurement inputs with cable break detection or additional temperature measurement
- Alarm outputs

○ UMG 96-PA SERIES

RCM & ENERGY MEASUREMENT

Secondary distribution

The UMG 96RM-E has 6 current inputs (4 inputs for 1 or 5 A and 2 analog inputs 0...30 mA), of which 2 analog inputs can be used for temperature or residual current measurement. It combines five functions in one compact device: Universal measurement device, energy monitoring, harmonics analysis and power quality as well as residual current monitoring.

Continuous monitoring of the residual current in current distributions is thus possible in addition to the normal measurement of the operating currents. A special procedure

is implemented for the RCM measurement which sets RCM limit values dynamically in dependence on the total power. Dynamic limit value formation allows a tailor-made residual current limit value to be created in all load ranges, thus avoiding unnecessary error alarms. In contrast to conventional RCM monitoring devices, an optimum residual current limit value is ensured even in the low-load range.

Residual currents and leakage currents are detected and recorded with reference to ground according to IEC 60755 type A and B.

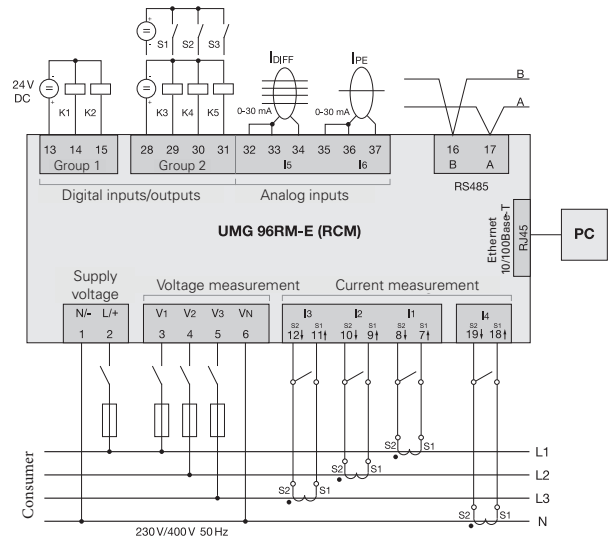

- Highest possible safety: Continuous residual current measurement
- Analysis of residual current events
- Analysis of the harmonic residual current components
- SNMP alarms
- Email alarms
- Historical data – long-term monitoring of measured variables
- RCM limit values can be optimized for each use case – with a fixed or dynamic limit value
- RCM diagnostic variables
- Alarm outputs

OPERATION & DISPLAY DIRECTLY ON SITE

The Smart Energy Panel JPC 100-WEB is used for optimal, centralized displaying and monitoring of RCM and energy measurement values. The integration of Modbus slave devices (e.g. Janitza UMG 103-CBM) is accomplished using the gateway function of the master device or directly via the RS485 interface. Direct access to the device homepage, optionally also via remote access, is provided by the Smart Energy Panel's web capability. Remote access is also possible via TeamViewer. A USB port supports easy export of measurement data.

The GridVis® Power Grid Monitoring Software can be used to evaluate, document and process the energy data. Grid-Vis® offers comprehensive reporting for this purpose. The limit values for voltage, current, RCM and power defined initially can be filtered, acknowledged and stored, and a clear display of exceedances allows hazards to be identified at an early stage. In addition, the "Email Notification"-function can be activated in case thresholds are exceeded.

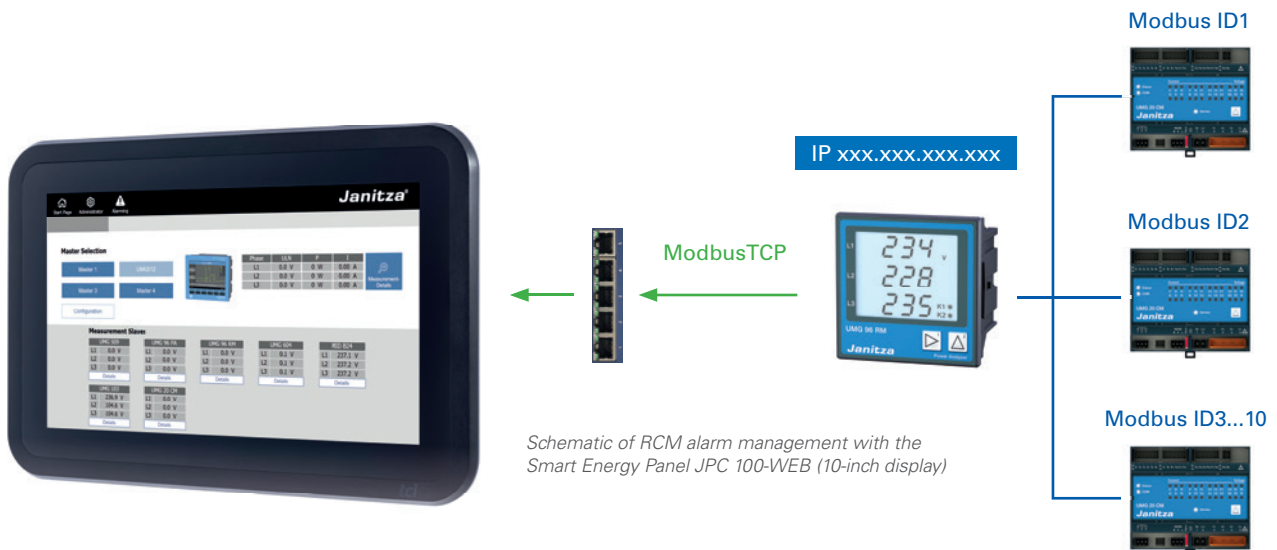

- | | | |
|---|--|--|
| <ul style="list-style-type: none"> ■ Visualization of the main and secondary measurements directly on site ■ Display of all RCM, current and energy measured values ■ Display and storage of the last min. and max. values | <ul style="list-style-type: none"> ■ Topology view of the circuits ■ Dynamic topology configuration of up to 33 devices ■ Plug & play configuration via USB: Import and export of device configurations | <ul style="list-style-type: none"> ■ Labeling of the individual circuits and limit values can be set per channel, etc. ■ Integrated alarm management ■ Email alarms ■ Password protected display |
|---|--|--|

SMART ENERGY PANEL JPC 100-WEB

RESIDUAL CURRENT MONITORING ON 20 CHANNELS

End consumers and final circuits

The multi-channel operating and residual current monitoring device UMG 20CM with connectable current measuring transformers is used for operating current measurement or alternatively for RCM measurement. It is used especially in applications with many outgoing feeders, such as in PDUs for data centers or final circuits in the building sector. 20 current measuring channels (inputs) are available for

connecting the current transformers for 0 - 600 A operating current measurement and for residual current measurement from 10 mA to 15 A. RS485 (Modbus RTU) is implemented as the communication interface. The limit value programming and alarm message option inform you immediately if your energy distribution system is overloaded.

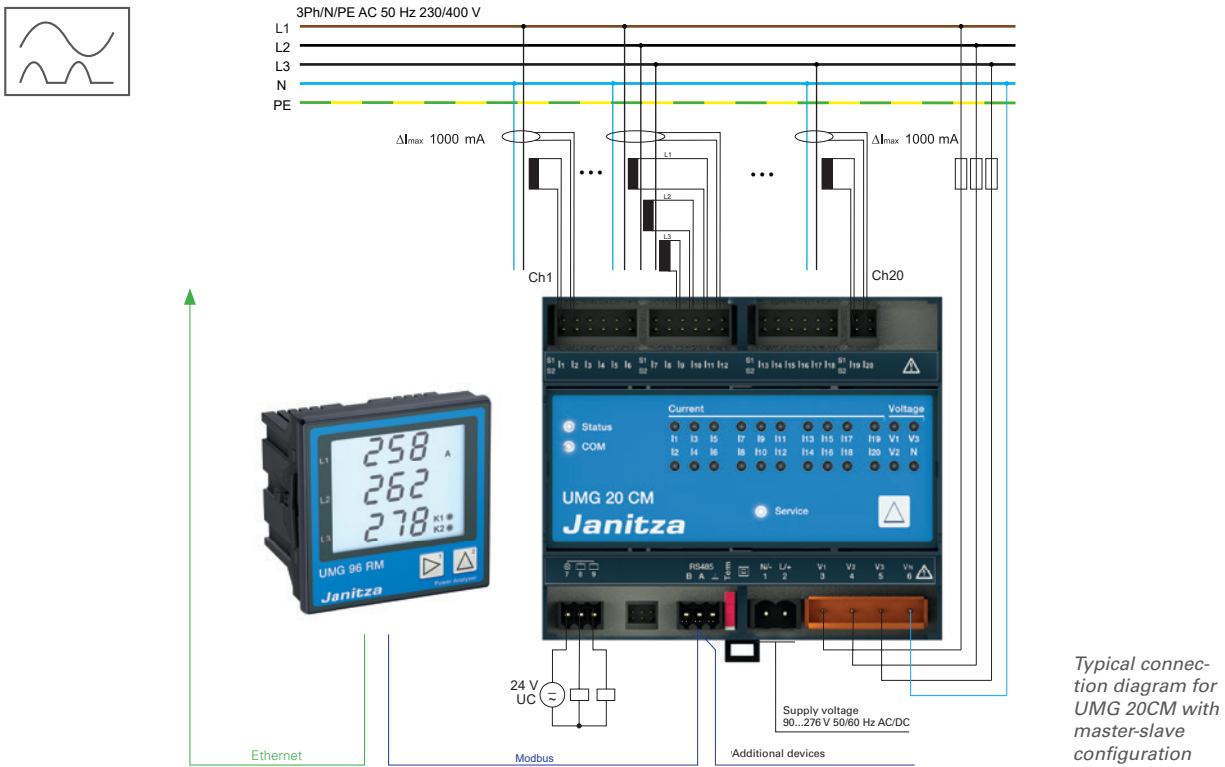

- RCM and energy measurement device all in one
- 20 current measuring channels: 20 LEDs – one LED for each current channel
- Compactness of the system: facilitates retrofitting in existing plants
- Analysis of the harmonic residual current components
- RCM diagnostic variables
- Alarm outputs
- Flexible use of the individual current measuring channels for RCM or energy measurement

EXPANDABLE WITH ADDITIONAL MEASURING CHANNELS

End consumers and final circuits

The 20CM-CT6 current and consumption monitoring device is intended for use in industrial and residential areas. It is suitable for the measurement and calculation of electrical quantities such as operating and residual current, power, energy, harmonics, etc. and is intended for use in building installations on distribution boards, circuit breakers and busbar trunking systems. The 20CM-CT6 is an expansion module with 20 current measurement channels for the UMG 20CM residual current monitoring device. Together with display devices or devices for

data coupling to external systems, they form a complete power and consumption monitoring system. With this monitoring system, system and operational safety are increased and energy flows to the end circuit become transparent. For example, malfunctions or the occurrence of a (usually creeping) increase in residual currents are detected early so that preventive maintenance is possible.

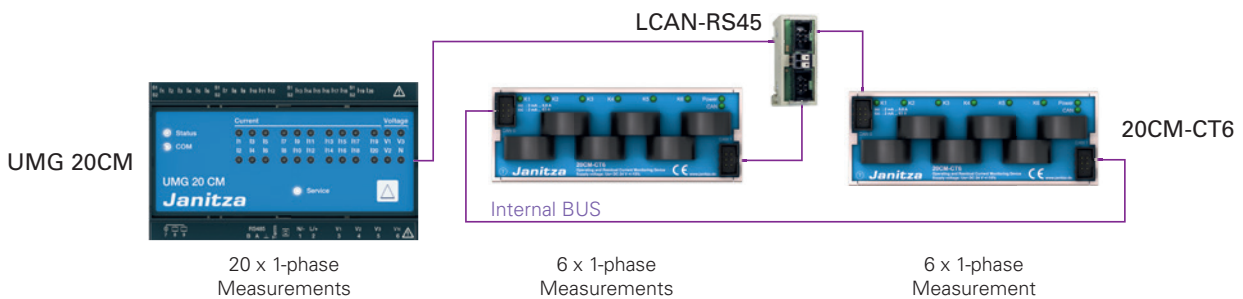

- System expandable to up to 96 current channels
- Measured value acquisition in parallel via six integrated current transformers
- Automatic switching between the measuring ranges
- Frequency analysis
- High-resolution: 2 mA – 63 A
- History memory
- Communication and power supply via internal bus, e.g. measured voltages received from the 20CM-CT6
- Parametrization via GridVis®
- RCM diagnostic variables
- Evaluation of residual currents (differential currents) of type A according to IEC 62020
- Generation of warning and triggering messages when limit values are exceeded
- Display of the limit value monitoring status using 6 LEDs

MONITORING OF RESIDUAL CURRENTS, TYPE A TO B+

Can be used at all measuring levels

The two-channel residual current monitoring device meets the requirements of the DIN EN 62020 standard. A recurring insulation test can be omitted or at least limited. Typical applications are low-voltage main distribution boards (LV MDB) and subdistribution panels (SDP) in grounded systems (e.g. TN-S systems). The RCM 202-AB is a technical alternative usable across all industries when power interruptions due to a residual current circuit breaker (RCD) or insulation resistance measurement cannot be tolerated.

Complete integration into the GridVis® Power Grid Monitoring Software is possible. The device can be integrated directly via the RS485 interface. It can be used as an RCM at any point, e.g. direct current systems, frequency converters, or applications with increased fire protection requirements. The RCM 202-AB allows type B/ type B+ monitoring with normal passive residual current transformers.

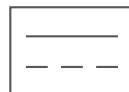

- Residual current measurement, up to 2 residual current transformers
- Measuring range, AC/DC 10 mA ... 20 A
- Detection, evaluation and monitoring of residual current types A, B and B+ according to DIN EN 62020
- Evaluation of AC and DC
- Harmonics spectrum up to 2 kHz, type B
- Mixed current up to 20 kHz, type A, type B+
- Memory for measured values and extreme values with time stamp
- High resolution LCD display with intuitive operation
- Peripherals:
 - 2 analog outputs
 - 2 alarm outputs
 - compatible with RCM inputs of the UMG 96RM-E & UMG 96-PA with RCM module
- RS485 interface (protocol: Modbus RTU)
- Patented measuring method

TYPE A MEASUREMENT WITH A ROGOWSKI COIL

Busbar and large conductor cross-sections

The RCM 201-ROGO residual current monitoring device complies with standard DIN EN 62020 and is used to monitor systems and consumers that have to be operated without interruption. It is perfectly suited for testing for residual currents of > 100 mA in TN-S systems. The main application of the stand-alone device is the measurement of Type A residual current for large cross section or busbar systems. In combination with a Rogowski coil (included in delivery), the user enjoys flexibility even in confined spaces and also benefits from the retrofitting capability of the measurement device.



Flexible measuring current transformer in different lengths:

- Space-saving and fast installation
- Easy retrofitting in existing systems
- No shutdown of the system required for installation
- Analog output for external measurement devices provided

- High measuring accuracy: 1% of measuring range

- Measurement of residual currents in the measuring ranges 5 / 10 / 25 / 125 A

- Standards-compliant to DIN EN 62020

- Recording, evaluation and monitoring of type A residual currents

- Rogowski RCM current transformers for large cable cross sections and busbars up to 4000 A

- Configurable limit values and alarm output via digital output and Modbus

- Compatible with Janitza UMG's RCM inputs

- RS485 interface (protocol: Modbus RTU)

- Compatible with all communication-enabled Janitza Modbus master devices

NETWORK VISUALIZATION SOFTWARE

A FUNDAMENTAL COMPONENT FOR RCM MONITORING AND ANALYSIS

GridVis® RCM Report

- Meaningful statistics on exceedances of limit values for residual currents and operational interruptions
- Support for system testing and the obligation to provide verification
- Verification of a "clean" TN-S system
- Optimal for large systems with many RCM measurement points
- Support of devices with dynamic limit value monitoring or static limit values
- Status overview with signal colors for a general overview

RCM Report Janitza

Parameter	Value	Unit	Limit	Status
Start Date	05.12.2018			
End Date	30.11.2018			
Network	TN-S			
Threshold 1	30 mA		→ 0	OK
Threshold 2	100 mA		→ 1	Warning
Threshold 3	not configured		→ 2	Alarm
Warning Threshold	not set			

Measurement Point	Device	Status
GG006 UV-GRF 8 B0.07 C01 R01/CAB01-07 R01/CAB01-08	Differenzstrom	Present
GG006 UV-GRF 8 B0.07 C01 R01/CAB01-07 R01/CAB01-09	Differenzstrom	Present
GG006 UV-GRF 8 B0.07 C01 R01/CAB01-07 R01/CAB01-10	Differenzstrom	Present
GG006 UV-GRF 8 B0.07 C01 R01/CAB01-07 R01/CAB01-11	Differenzstrom	Present
GG006 UV-GRF 8 B0.07 C01 R01/CAB01-07 R01/CAB01-12	Differenzstrom	Present
GG006 UV-GRF 8 B0.07 C01 R01/CAB01-07 R01/CAB01-13	Differenzstrom	Present
GG006 UV-GRF 8 B0.07 C01 R01/CAB01-07 R01/CAB01-14	Differenzstrom	Present
GG006 UV-GRF 8 B0.07 C01 R01/CAB01-07 R01/CAB01-15	Differenzstrom	Present
GG006 UV-GRF 8 B0.07 C01 R01/CAB01-07 R01/CAB01-16	Differenzstrom	Present
GG006 UV-GRF 8 B0.07 C01 R01/CAB01-07 R01/CAB01-17	Differenzstrom	Present
GG006 UV-GRF 8 B0.07 C01 R01/CAB01-07 R01/CAB01-18	Differenzstrom	Present
GG006 UV-GRF 8 B0.07 C01 R01/CAB01-07 R01/CAB01-19	Differenzstrom	Present
GG006 UV-GRF 8 B0.07 C01 R01/CAB01-07 R01/CAB01-20	Differenzstrom	Present
GG006 UV-GRF 8 B0.07 C01 R01/CAB01-07 R01/CAB01-21	Differenzstrom	Present
GG006 UV-GRF 8 B0.07 C01 R01/CAB01-07 R01/CAB01-22	Differenzstrom	Present
GG006 UV-GRF 8 B0.07 C01 R01/CAB01-07 R01/CAB01-23	Differenzstrom	Present
GG006 UV-GRF 8 B0.07 C01 R01/CAB01-07 R01/CAB01-24	Differenzstrom	Present
GG006 UV-GRF 8 B0.07 C01 R01/CAB01-07 R01/CAB01-25	Differenzstrom	Present
GG006 UV-GRF 8 B0.07 C01 R01/CAB01-07 R01/CAB01-26	Differenzstrom	Present
GG006 UV-GRF 8 B0.07 C01 R01/CAB01-07 R01/CAB01-27	Differenzstrom	Present
GG006 UV-GRF 8 B0.07 C01 R01/CAB01-07 R01/CAB01-28	Differenzstrom	Present
GG006 UV-GRF 8 B0.07 C01 R01/CAB01-07 R01/CAB01-29	Differenzstrom	Present
GG006 UV-GRF 8 B0.07 C01 R01/CAB01-07 R01/CAB01-30	Differenzstrom	Present
GG006 UV-GRF 8 B0.07 C01 R01/CAB01-07 R01/CAB01-31	Differenzstrom	Present
GG006 UV-GRF 8 B0.07 C01 R01/CAB01-07 R01/CAB01-32	Differenzstrom	Present
GG006 UV-GRF 8 B0.07 C01 R01/CAB01-07 R01/CAB01-33	Differenzstrom	Present
GG006 UV-GRF 8 B0.07 C01 R01/CAB01-07 R01/CAB01-34	Differenzstrom	Present
GG006 UV-GRF 8 B0.07 C01 R01/CAB01-07 R01/CAB01-35	Differenzstrom	Present
GG006 UV-GRF 8 B0.07 C01 R01/CAB01-07 R01/CAB01-36	Differenzstrom	Present
GG006 UV-GRF 8 B0.07 C01 R01/CAB01-07 R01/CAB01-37	Differenzstrom	Present
GG006 UV-GRF 8 B0.07 C01 R01/CAB01-07 R01/CAB01-38	Differenzstrom	Present
GG006 UV-GRF 8 B0.07 C01 R01/CAB01-07 R01/CAB01-39	Differenzstrom	Present
GG006 UV-GRF 8 B0.07 C01 R01/CAB01-07 R01/CAB01-40	Differenzstrom	Present
GG006 UV-GRF 8 B0.07 C01 R01/CAB01-07 R01/CAB01-41	Differenzstrom	Present
GG006 UV-GRF 8 B0.07 C01 R01/CAB01-07 R01/CAB01-42	Differenzstrom	Present
GG006 UV-GRF 8 B0.07 C01 R01/CAB01-07 R01/CAB01-43	Differenzstrom	Present
GG006 UV-GRF 8 B0.07 C01 R01/CAB01-07 R01/CAB01-44	Differenzstrom	Present
GG006 UV-GRF 8 B0.07 C01 R01/CAB01-07 R01/CAB01-45	Differenzstrom	Present
GG006 UV-GRF 8 B0.07 C01 R01/CAB01-07 R01/CAB01-46	Differenzstrom	Present
GG006 UV-GRF 8 B0.07 C01 R01/CAB01-07 R01/CAB01-47	Differenzstrom	Present
GG006 UV-GRF 8 B0.07 C01 R01/CAB01-07 R01/CAB01-48	Differenzstrom	Present
GG006 UV-GRF 8 B0.07 C01 R01/CAB01-07 R01/CAB01-49	Differenzstrom	Present
GG006 UV-GRF 8 B0.07 C01 R01/CAB01-07 R01/CAB01-50	Differenzstrom	Present

GridVis® RCM Report as proof of testing



- Residual current 2
- Residual current 3
- Residual current 1

RCM – VISUALIZATION, ALARMING, ANALYSIS AND REPORTING

With GridVis®, technicians and business managers receive the data necessary to:

- Receive early alerts before a failure
- Identify failures and vulnerabilities
- Evaluate high-level availability as a whole
- Create a basis for predictive maintenance
- Calculate key performance indicators
- Present cost centers
- Monitor status messages

GridVis®– convenient and versatile

- Convenient programming and parameter configuration
- Link measurement points & create dashboards
- Web-based alarm manager with escalation management
- Versatile presentations
- Automated reports and exports
- Histories and topologies
- Analysis of the effects of nonlinear loads and filter currents
- Integration of RCM systems from other manufacturers via OPC UA or Modbus



GridVis®
System and energy monitoring
at the highest level

Measurement of the CGP
(central grounding point)

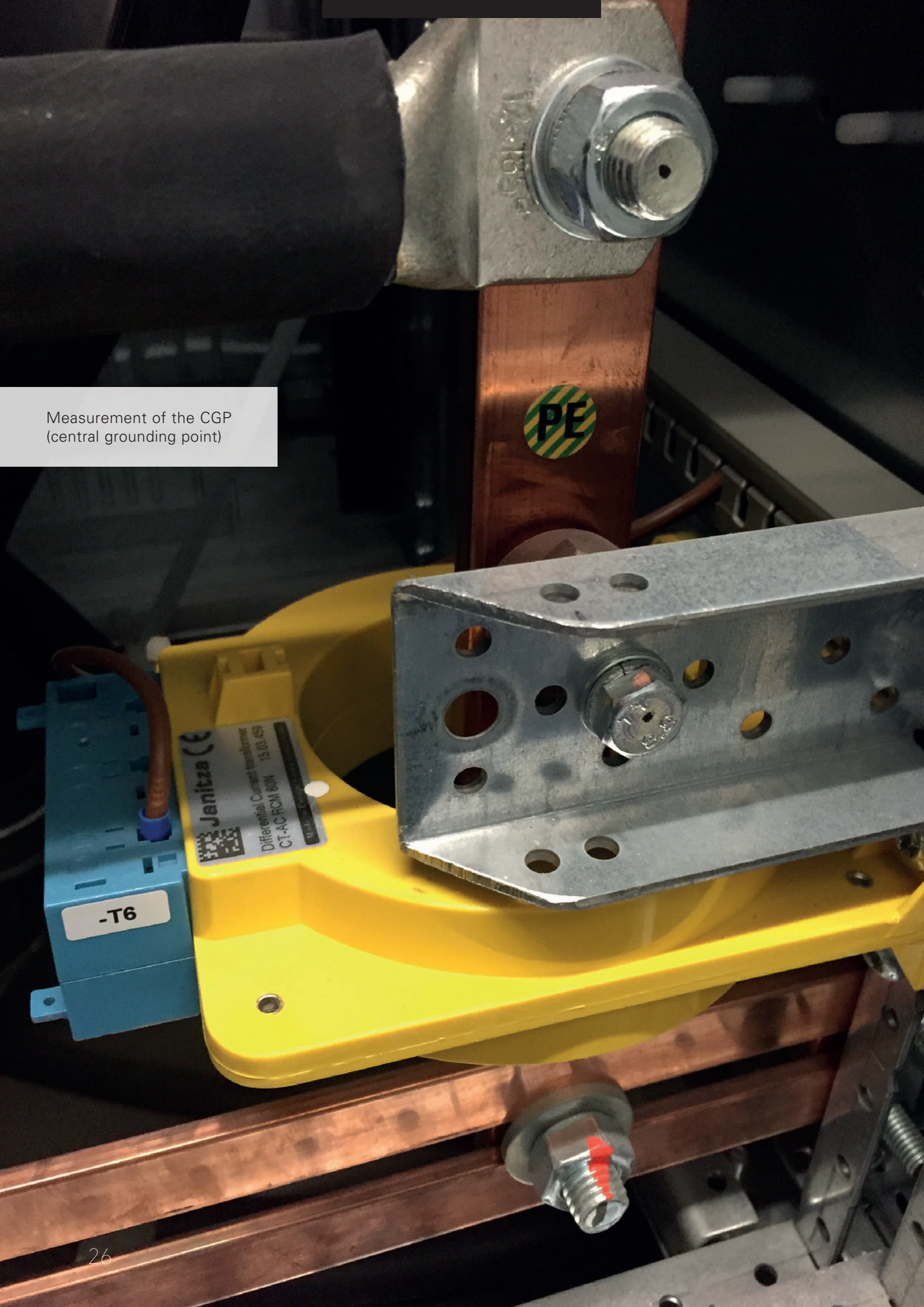

OVERVIEW

FEEDTHROUGH RESIDUAL CURRENT TRANSFORMER, TYPE A

Detection of very small currents

- Type CT-AC RCM 35N to 210N
- In combination with the UMG measurement devices, the residual current of machines or systems can be determined relative to ground
- Compact design
- Suitable for the UMG 96RM-E, UMG 96RM-PN, UMG 20CM, UMG 509-PRO, UMG 512-PRO
- With RCM 202-AB, type B+ measurement possible

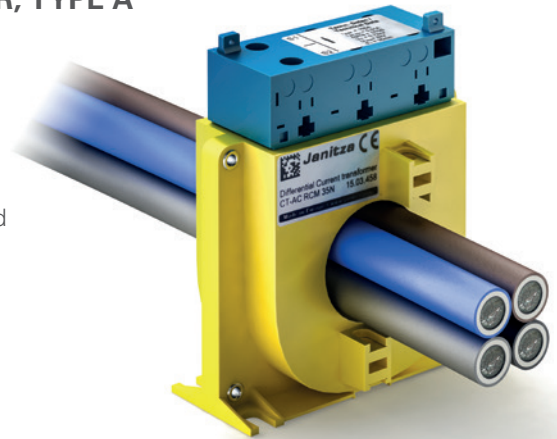

SPLIT-CORE RESIDUAL CURRENT TRANSFORMER, TYPE A

Reliable handling and compact

- Type KBU 23D to 812D
- Simple and cost-effective installation
- Practical locking system: No need to disconnect and remove the primary conductors
- Available in various dimensions
- No interruption of operation
- Suitable for the UMG 96RM-E, UMG 96RM-PN, UMG 20CM, UMG 509-PRO, UMG 512-PRO
- With RCM 202-AB, type B+ measurement possible

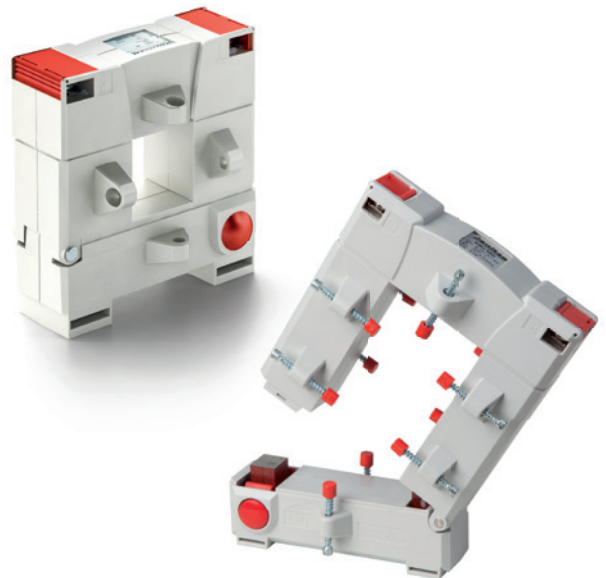

SPLIT-CORE RESIDUAL CURRENT TRANSFORMER, TYPE A

Reliable handling and retrofittable

- Type CT-AC RCM A110N to A310N
- In combination with the UMG measurement devices, the residual current of machines or systems can be determined relative to ground (e.g. insulation faults).
- Compact design
- Detection of very small currents
- Suitable for the UMG 96RM-E, UMG 96RM-PN, UMG 20CM, UMG 509-PRO, UMG 512-PRO
- With RCM 202-AB, type B+ measurement possible

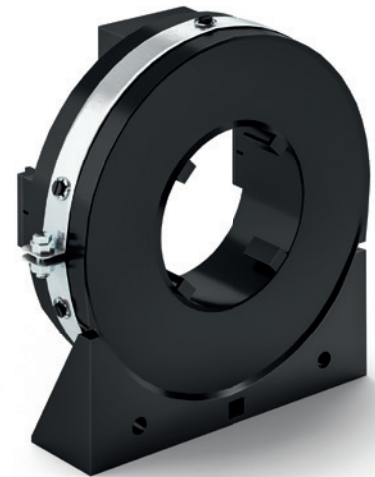

RESIDUAL CURRENT TRANSFORMER, TYPE A

Residual current detection in 3-/4-conductor alternating current networks

- Type DACT 20
- Highly sensitive current sensor for detecting even the smallest residual currents
- Simple connection by means of 4-pole spring terminal
- High level of safety thanks to integrated overvoltage protection
- Flexible use due to a wide frequency range
- Applied technical standards: IEC 60664-1 / IEC 60664-3
- Suitable for the UMG 96RM-E, UMG 96RM-PN, UMG 20CM, UMG 509-PRO, UMG 512-PRO
- With RCM 202-AB, type B+ measurement possible



RESIDUAL CURRENT TRANSFORMER, TYPE B+

Always watchful – intelligent transducers

- Type CT-AC/DC type B+ 35 RCM to 70 RCM
- Detection of residual currents of type B+ (up to 300 mA)
- Pre-alarm in the event of a malfunction
- Standard interface, 4-20 mA
- Continuous monitoring of residual currents
- 24 VDC supply voltage
- Compact, robust plastic housing
- Reduction of German Social Accident Insurance V3 (replacement for insulation measurement in stationary electrical systems)
- Simple implementation of fire and system protection
- Decentralized direct shutdown of system components
- Suitable for the UMG 96RM-E



OPERATING OR RESIDUAL CURRENT TRANSFORMER, TYPE A

Precise and efficient

- Type CT-20
- Suitable for operating currents up to max. 63 A and for residual currents from 1 mA to 1,000 mA according to type A
- Compact design
- Ratio 700/1
- Primary window applicable for insulated cable \varnothing 7.5 mm (max.)
- For use on a 3-phase circuit breaker with a phase distance of 17.5 mm
- DIN rail mounting (35 mm) via rail clamp (optional)
- Specially designed for the UMG 20CM
- Suitable for the UMG 96RM-E, UMG 96RM-PN, UMG 20CM, UMG 509-PRO, UMG 512-PRO



SPLIT-CORE CURRENT TRANSFORMER FOR RESIDUAL CURRENT, TYPE A

Microfine and high-precision

- Type SC-CT-21
- Compact, separable split-core current transformer
- Suitable for residual current measurement (10 ... 1000 mA)
- High measuring accuracy
- Simple installation by means of clip technology
- UL and EN 61010-1 certified
- Especially for use with the UMG 20CM
- Suitable for the UMG 96RM-E, UMG 96RM-PN, UMG 20CM, UMG 509-PRO, UMG 512-PRO



6-FOLD DIN RAIL CURRENT TRANSFORMER, OPERATING OR RESIDUAL CURRENT, TYPE A

Monitor, detect and act

- Type CT-6-20
- Residual current detection with integrated current transform (residual currents according to IEC 60755 type A)
- 6 measuring channels
- Compact design
- Measured value acquisition and processing in parallel
- Use in distribution outgoing feeders for consumers and syst
- Specially designed for the UMG 20CM

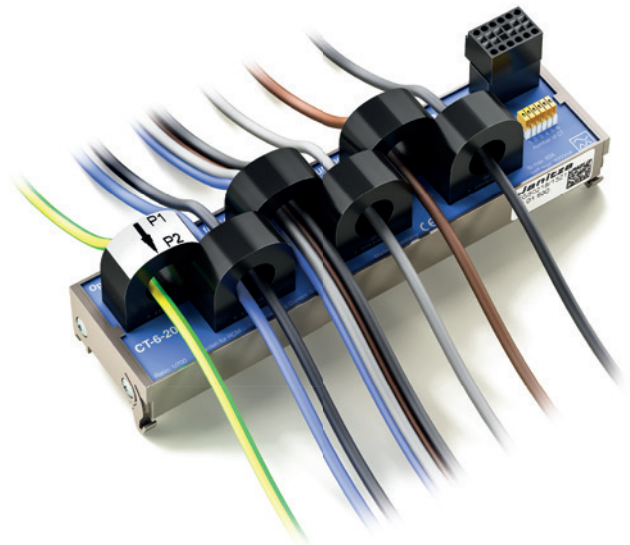

Residual current transformer

COMPATIBILITY LIST FOR RESIDUAL CURRENT TRANSFORMERS

RCM transformer type	Interior window	Separable Yes/No	Residual current type	Transformer ratio	Primary current with evaluation unit ¹	Primary current with UMG 20CM	Primary current with RCM 202-AB	Compatibility evaluation unit ²	Compatibility RCM 202-AB
DACT20	20 mm round	No	Type A (type B with RCM 202-AB)	600/1	18000 mA	1000 mA without load 16000 mA with load	20 A AC / 20 A DC	Yes	Yes
CT-AC RCM 35N	35 mm round	No	Type A (type B with RCM 202-AB)	700/1	21000 mA	1000 mA without load 16000 mA with load	20 A AC / 20 A DC	Yes	Yes
CT-AC RCM 80N	80 mm round	No	Type A (type B with RCM 202-AB)	700/1	21000 mA	1000 mA without load 16000 mA with load	20 A AC / 20 A DC	Yes	Yes
CT-AC RCM 110N	110 mm round	No	Type A (type B with RCM 202-AB)	700/1	21000 mA	1000 mA without load 16000 mA with load	20 A AC / 20 A DC	Yes	Yes
CT-AC RCM 140N	140 mm round	No	Type A (type B with RCM 202-AB)	700/1	21000 mA	1000 mA without load 16000 mA with load	20 A AC / 20 A DC	Yes	Yes
CT-AC RCM 210N	210 mm round	No	Type A (type B with RCM 202-AB)	700/1	21000 mA	1000 mA without load 16000 mA with load	20 A AC / 20 A DC	Yes	Yes
CT-20	75 mm round	No	Type A	700/1	21000 mA	1000 mA without load 16000 mA with load	Not compatible	Yes	Not compatible
SC-CT-21	8.5 mm round	Yes	Type A	700/1	21000 mA	1000 mA without load 16000 mA with load	Not compatible	Yes	Not compatible
CT-AC RCM A110N	110 mm round	Yes	Type A (type B with RCM 202-AB)	700/1	21000 mA	1000 mA without load 16000 mA with load	20 A AC / 20 A DC	Yes	Yes
CT-AC RCM A150N	150 mm round	Yes	Type A (type B with RCM 202-AB)	700/1	21000 mA	1000 mA without load 16000 mA with load	20 A AC / 20 A DC	Yes	Yes
CT-AC RCM A310N	310 mm round	Yes	Type A (type B with RCM 202-AB)	700/1	21000 mA	1000 mA without load 16000 mA with load	20 A AC / 20 A DC	Yes	Yes
KBU 23D	20 mm x 30 mm rectangular	Yes	Type A (type B with RCM 202-AB)	600/1	18000 mA	1000 mA without load 16000 mA with load	20 A AC / 20 A DC	Yes	Yes
KBU 58D	50 mm x 80 mm rectangular	Yes	Type A (type B with RCM 202-AB)	600/1	18000 mA	1000 mA without load 16000 mA with load	20 A AC / 20 A DC	Yes	Yes
KBU 812D	80 mm x 120 mm rectangular	Yes	Type A (type B with RCM 202-AB)	600/1	18000 mA	1000 mA without load 16000 mA with load	20 A AC / 20 A DC	Yes	Yes
CT-AC/DC type B+ 35 RCM	35 mm round	No	Type B+ (AC and DC)	4-20 mA (300 mA/5 A)	300 mA	Not compatible	Not compatible	Only UMG 96RM-E, module 96-PA-RCM, module 96-PA-RCM-EL	Not compatible
CT-AC/DC type B+ 70 RCM	70 mm round	No	Type B+ (AC and DC)	4-20 mA (300 mA/5 A)	300 mA	Not compatible	Not compatible	Only UMG 96RM-E, module 96-PA-RCM, module 96-PA-RCM-EL	Not compatible

¹ UMG 96RM-E, UMG 509-PRO, UMG 512-PRO, UMG 96RM-PN, 96-PA-RCM module, 96-PA-RCM-EL module

² UMG 96RM-E, UMG 509-PRO, UMG 512-PRO, UMG 96RM-PN, UMG 20CM, 96-PA-RCM module, 96-PA-RCM-EL module

Further information and the detailed RCM white paper can be found at:
<https://www.janitza.com/whitepaper-about-rcm.html>



Janitza electronics GmbH
Vor dem Polstück 6 | 35633 Lahnau
Germany

Phone: +49 6441 9642-0
info@janitza.com | www.janitza.com

Sales partner

Item no.: 33.03.657 • Doc. no.: 2.500.075.5 • Version 06/2020 • Subject to technical alterations.
The latest version of the brochure is available at www.janitza.com